

**WASTE PACKAGE SPECIFICATION AND
GUIDANCE DOCUMENTATION**

**WPS/810: Wasteform Specification for 3 cubic
metre Boxes and 3 cubic metre Drum Waste
Packages: Explanatory Material
and Design Guidelines
March 2008
Number: 8766683**

**WASTE PACKAGE SPECIFICATION AND
GUIDANCE DOCUMENTATION**

**WPS/810: Wasteform Specification for 3 cubic
metre Boxes and 3 cubic metre Drum Waste
Packages: Explanatory Material
and Design Guidelines**

March 2008

Number: 8766683

Conditions of Publication

This report is made available under the NDA Transparency Policy. In line with this policy, the NDA is seeking to make information on its activities readily available, and to enable interested parties to have access to and influence on its future programmes. The report may be freely used for non-commercial purposes. However, all commercial uses, including copying and re-publication, require permission from the NDA. All copyright, database rights and other intellectual property rights reside with the NDA. Applications for permission to use the report commercially should be made to the NDA Information Manager.

Although great care has been taken to ensure the accuracy and completeness of the information contained in this publication, the NDA can not assume any responsibility for consequences that may arise from its use by other parties.

© Nuclear Decommissioning Authority 2008. All rights reserved.

Bibliography

If you would like to see other reports available from NDA, a complete listing can be viewed at our website www.nda.gov.uk, or please write to the Library at the address below.

Feedback

Readers are invited to provide feedback to the NDA on the contents, clarity and presentation of this report and on the means of improving the range of NDA reports published. Feedback should be addressed to:

John Dalton,
Head of Communications,
NDA Harwell
Radioactive Waste Management Directorate
Curie Avenue,
Harwell,
Didcot,
Oxon,
OX11 0RH, UK.

john.dalton@nda.gov.uk

WASTE PACKAGE SPECIFICATION AND GUIDANCE DOCUMENTATION
WASTEFORM SPECIFICATION FOR 3 CUBIC METRE BOXES AND DRUM WASTE
PACKAGES: EXPLANATORY MATERIAL AND DESIGN GUIDELINES

This document forms part of a suite of documents prepared and issued by the Radioactive Waste Management Directorate (RWMD) of the Nuclear Decommissioning Authority (NDA).

The Waste Package Specification and Guidance Documentation (WPSGD) provide specifications and guidance for waste packages, containing Intermediate Level Waste and certain Low Level Wastes, which meet the transport and disposability requirements of geological disposal in the UK. They are based on, and are compatible with, the Generic Waste Package Specification (GWPS).

The WPSGD are intended to provide a 'user-level' interpretation of the GWPS to assist Site License Companies (SLCs) in the early development of plans and strategies for the management of radioactive wastes. To aid in the interpretation of the criteria defined by the WPSGD, and in their application to proposals for the packaging of wastes, SLCs are advised to contact RWMD at an early stage.

The WPSGD will be subject to periodic enhancement and revision. SLCs are therefore advised to contact RWMD to confirm that they are in possession of the latest version of any documentation used.

WPSGD DOCUMENT NUMBER WPS/810 - VERSION HISTORY		
VERSION	DATE	COMMENTS
WPS/810/01	December 2005	Aligns with GWPS (Nirex Report N/104) as published June 2005
WPS/810/02	March 2008	Responsibility for the WPSGD passed to the NDA RWMD. Aligns with Issue 2 of GWPS (Nirex Report N/104) as published March 2007. Includes changes resulting from updated DBA methodology and changes to NII SAPs

This document has been compiled on the basis of information obtained by Nirex and latterly by the NDA. The document was verified in accordance with arrangements established by the NDA that meet the requirements of ISO 9001. The document has been fully verified and approved for publication by the NDA.

CONTENTS

1	INTRODUCTION	1
2	BACKGROUND	2
2.1	The Concept of Geological Disposal	2
2.2	The Generic Waste Package Specification	3
2.3	The Assessment of Packaging Proposals	3
3	THE 3 CUBIC METRE BOX AND DRUM WASTE PACKAGES	4
4	WASTEFORM SPECIFICATION CRITERIA	6
5	WASTEFORM PROPERTIES	6
5.1	Physical Immobilisation	6
5.2	Mechanical and Physical Properties	10
5.3	Chemical Containment	15
5.4	Hazardous Materials	18
5.5	Gas Generation	20
5.6	Wasteform Evolution	24
5.7	Nuclear Properties	31
6	GUIDANCE QUANTITIES FOR WASTEFORM CONTENTS	33
7	REFERENCES	43

1 INTRODUCTION

The Radioactive Waste Management Directorate (RWMD) of the Nuclear Decommissioning Authority (NDA) has been established with the remit to implement the geological disposal option for the UK's higher activity radioactive wastes. The NDA is currently working with Government and stakeholders through the Managing Radioactive Waste Safely (MRWS) consultation process to plan the development of a Geological Disposal Facility (GDF).

As the ultimate receiver of wastes, RWMD, acting as GDF implementer and future operator, has established waste packaging standards and defined package specifications to enable the industry to condition radioactive wastes in a form that will be compatible with future transport and disposal. In this respect RWMD is taking forward waste packaging standards and specifications which were originally developed by United Kingdom Nirex Ltd, which ceased trading on 1st April 2007 and whose work has been integrated into the NDA.

The primary document which defines the packaging standards and specifications for Intermediate Level Waste (ILW), and certain Low Level Wastes (LLW) not suitable for disposal in other LLW facilities is the Generic Waste Package Specification (GWPS) [1]. The GWPS is supported by the Waste Package Specification and Guidance Documentation (WPSGD) which comprises a suite of documentation primarily aimed at waste packagers, its intention being to present the generic packaging standards and specifications at the user level. The WPSGD also includes explanatory material and guidance that users will find helpful when it comes to application of the specification to practical packaging projects. For further information on the extent and the role of the WPSGD, reference should be made to the Introduction to the Waste Package Specification and Guidance Documentation, WPS/100¹.

In order to facilitate the safe and efficient packaging, transport and disposal of radioactive waste, RWMD has defined a limited range of standard waste containers. Included within the WPSGD are documents which define standards and specifications for the waste packages that are created using these containers, together with specifications for the wasteforms contained within them. For each standard waste package a suite of four documents exists:

WPS/300 Series – Waste Package Specification

WPS/500 Series – Wasteform Specification

WPS/700 Series – Guidance on Waste Package Specification

WPS/800 Series – Guidance on Wasteform Specification

This document provides guidance on Wasteform Specification for 3 cubic metre Boxes and Drum Waste Packages, WPS/510, which itself augments the high level wasteform specification contained within the WPS/300 Series documents and the supporting guidance in the WPS/700 Series documents.

¹ Specific references to individual documents within the WPSGD are made in this document in *italic script*, followed by the relevant WPS number.

2 BACKGROUND

2.1 The Concept of Geological Disposal

A key aspect in the production of standards and specifications for packaged waste is the definition of a disposal system which encompasses all stages of the long-term management of waste from retrieval through to final disposal.

In line with the MRWS consultation process, RWMD are continuing to develop concepts for the geological disposal for higher activity wastes which include ILW, and certain LLW not suitable for disposal in other LLW facilities². It is envisaged that the geological disposal of such wastes would comprise a number of distinct stages including:

- the retrieval and conditioning of the waste to create disposable waste packages, usually at the site of waste arising;
- a period of interim surface storage, also at the site of arising;
- transport of the waste packages to a GDF;
- transfer of waste packages underground and emplacement in disposal vaults;
- a period of monitored storage underground, during which retrieval by relatively simple means would be feasible;
- back-filling of the disposal vaults, followed by eventual sealing and closure.

The timing and duration of each stage would depend on a number of criteria, including the geographical location and host geology of a GDF as well as the disposal concept selected for implementation.

The Phased Geological Repository Concept (PGRC) [2], has been developed as one manifestation of geological disposal and has been adopted as the reference concept for the purposes of establishing packaging standards. The PGRC is supported by a suite of safety, security and environmental assessments intended to demonstrate that this concept will provide safety to workers and the public and provide the necessary level of environmental protection.

The safety philosophy adopted in the PGRC, in common with other approaches to the geological disposal of radioactive waste, is one of containment of radionuclides by multiple barriers, of which that provided by the waste package is a key component. Included in these barriers are those provided by the waste package, which itself can be considered as two independent but complimentary barriers, the waste container and the wastefrom, each of which plays an important role in the containment of radionuclides.

As the MRWS consultation process continues it is anticipated that the siting process, based on expressions of interest from volunteer communities, may lead to the identification of sites for investigation as to suitability to host a GDF. The disposal concept design and safety case will be developed to suit the specific characteristics of the site and packaging standards will be updated to reflect the new circumstances as appropriate.

² The generic description 'ILW' is used in the remainder of this document to describe both these categories of waste.

2.2 The Generic Waste Package Specification

A major area of the RWMD's work is the provision of advice to the packagers of radioactive waste in the UK, by way of the definition of packaging standards and the assessment of individual waste packaging proposals against those standards.

The primary document that defines packaging standards for ILW is the GWPS [1]. Derived from the PGRC and its associated generic documentation, which comprise the system specifications and safety assessments that define the PGRC, the GWPS provides the basis for assessing the suitability of waste packages containing ILW for disposal in a GDF.

The packaging standards defined by the GWPS are generic in two respects in that they are:

- derived from a full consideration of all future stage of long-term waste management; and
- independent of the location of the site of a GDF, which could be implemented at a range of different sites within the UK, representing a range of geological environments.

The format of the GWPS is to define:

- general requirements that are applicable to all waste packages;
- a range of standard waste containers;
- specific requirements for the standard waste package design that are created using the standard waste containers;
- requirements for the conditioned wasteforms that are placed into containers;
- requirements for quality management and for the creation and maintenance of records about each individual waste package.

The GWPS therefore defines the performance requirements for the two barriers to the release of radionuclides provided by the waste package, the waste container and the wasteform, against which the overall performance of waste packages can be assessed.

2.3 The Assessment of Packaging Proposals

Since the mid-1980s, waste producers in the UK have made significant investment in waste retrieval and packaging plant as a means of ensuring that such wastes are rendered passively safe and suitable for disposal. Historically Nirex was responsible for the assessment and endorsement of the suitability of packaging processes for this latter need, originally by way of the 'Letter of Comfort' assessment process. Over the ensuing two decades the Letter of Comfort process has developed and matured to a point that the assessments undertaken were established on a more structured footing with detailed advice being issued to waste producers highlighting further information needs, or need for further development and/or research before a Letter of Comfort could be issued. The assessment process was also modified to integrate better with the implementation of packaging plant projects, with staged interactions occurring at a number of stages before active operation of a packaging plant commenced. The status of the assessment process was strengthened in January 2004, when support was provided by UK nuclear regulators, and it was recognised within improved regulatory arrangements for nuclear licensed sites [3]. This was accompanied by significant changes to the assessment process which was renamed the 'Letter of Compliance' assessment process, a full description of which can be found in *Guide to the Letter of Compliance Assessment Process, WPS/650*.

In April 2007 Nirex was dissolved and its responsibilities assumed by RWMD. This included the role of assessing and endorsing nuclear site operators' waste packaging proposals through the LoC assessment process.

In undertaking LoC assessments RWMD determines whether wastes, when packaged, will have characteristics compliant with plans for transport to, and operations at a GDF, and ultimately whether the wastes could be accommodated within a GDF long-term post-closure safety case. The main output of a LoC assessment is an Assessment Report which may be accompanied by the issue of a LoC endorsing the packaging proposal. In line with the recently updated regulatory guidance [4] such endorsement is now seen by the regulators as an important component of the operator's Radioactive Waste Management Case.

3 THE 3 CUBIC METRE BOX AND DRUM WASTE PACKAGES

The GWPS defines three waste packages with a conditioned waste volume of approximately 3m³; two variants of the 3 cubic metre Box and the 3 cubic metre Drum. The 3 cubic metre Boxes (Figures 1 and 2) are typically used for the conditioning of ILW which includes larger items, typically legacy wastes stored at various nuclear facilities throughout the UK. The 3 cubic metre Drum (Figure 3) is primarily used for the conditioning of liquid, sludge and slurry wastes by a process of 'in-drum mixing' with an immobilising material such as cement. Fuller descriptions of all three waste packages can be found in the GWPS [1].

All three of the 3 cubic metre waste packages are known as 'unshielded waste package' in that they are typically manufactured from relatively thin stainless steel and, because of either external radiation levels or requirements for the containment of radionuclides, remote handling is usually required. For similar reasons, 3 cubic metre Box and Drum waste packages are usually transported in a reusable shielded transport container, the combination of waste package and transport container being classed as a Type B transport package under the IAEA Transport Regulations [5].

Figure 1 The side-lifting variant of the 3 cubic metre Box waste package

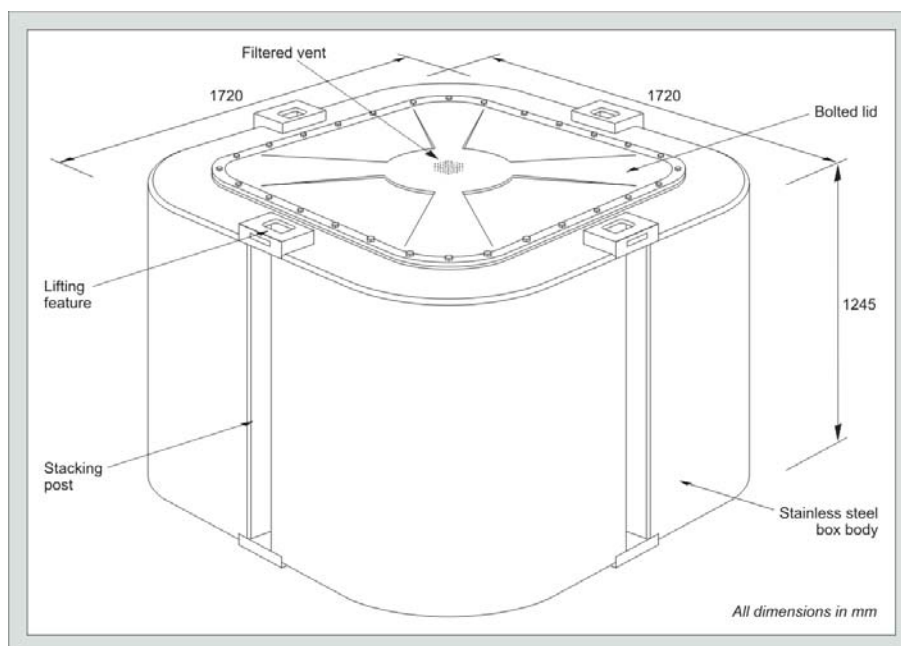

Figure 2 The corner-lifting variant of the 3 cubic metre Box waste package

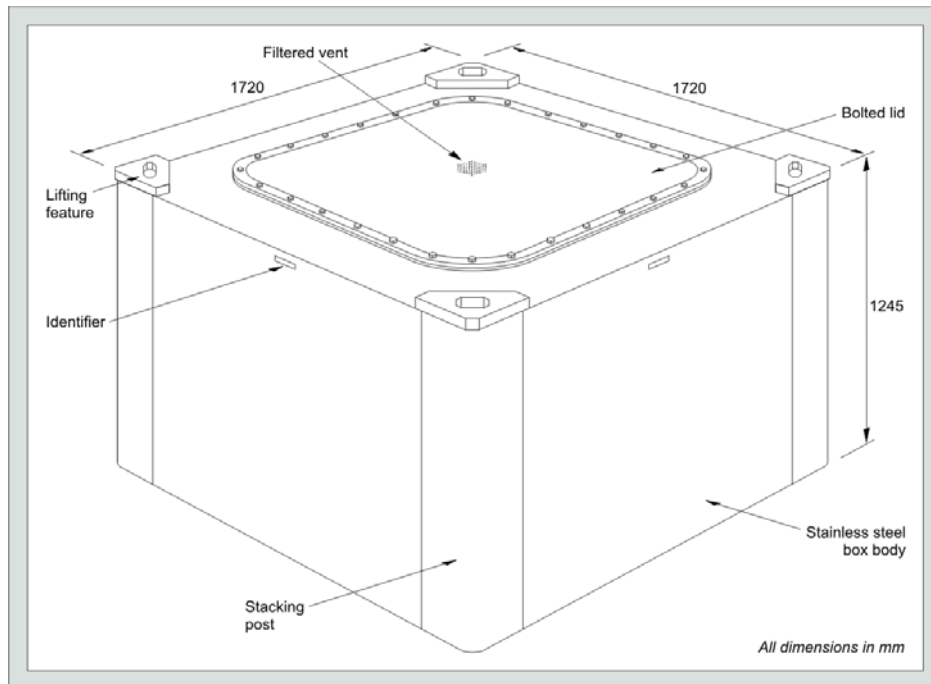
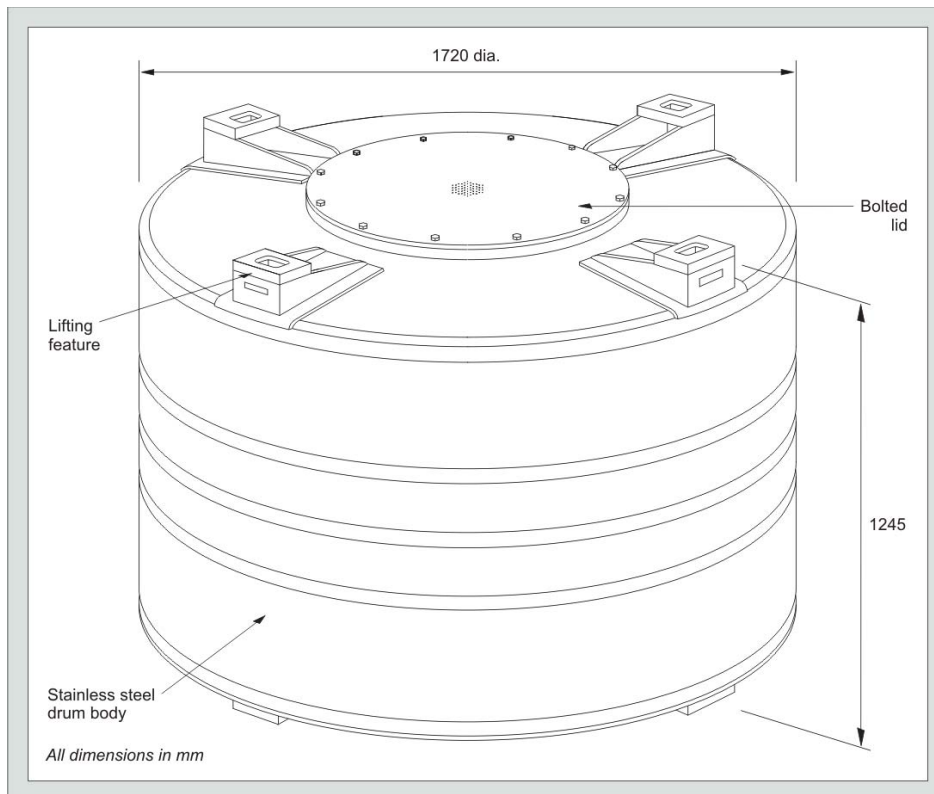

Figure 3 3 cubic metre Drum Waste Package



4 WASTEFORM SPECIFICATION CRITERIA

Section 4 of *Wasteform Specification for 3 cubic metre Boxes and 3 cubic metre Drum Waste Packages*, WPS/510 identifies the performance criteria that are required of the wasteforms for all waste package manufactured using the three standard 3 cubic metre waste containers, specified to ensure the compatibility of such waste packages with the needs of all stages of their long-term management. Where numerical criteria are specified the values stated are those that would be applicable at the time of transport from the waste packager's site (unless specifically stated otherwise).

Direct quotations from WPS/510 are shown in this document in ***bold blue italic type***. It should be noted that, where the words shall and should are used in criteria within the Specification, their use is consistent with the recommendations of BS 7373:1998 [6] and that they have the following meaning:

- **shall** denotes a criterion which is derived from consideration of a regulatory requirement and/or which forms the basis for package standardisation;
- **should** denotes a criterion which is considered as a target, and for which variations may be possible following discussion with RWMD.

5 WASTEFORM PROPERTIES

The principal functions of the wasteform are to immobilise radionuclides and to make hazardous materials safe. During transport and handling operations the wasteform should ensure that radioactivity is not present in a gaseous, volatile, liquid or fine particulate form to such an extent that the waste package will fail to meet the requirements of the relevant Waste Package Specification (WPS). The wasteform should be compatible with the waste container to ensure that the properties of the waste package as a whole meet the requirements of the WPS. After emplacement in a GDF the wasteform, together with the container, should provide a physical barrier to the release of radioactivity from the waste package and the wasteform, together with the backfill, should exert chemical control over the solubility of certain radionuclides in the waste.

The role of the wasteform during all stages of the long-term management of conditioned waste is to behave in a benign and predictable manner in order to prevent unpredictable waste package performance. This is particularly important during the earlier stages of the management of waste packages (i.e. during interim surface storage, transport and the operational period of a GDF) when the waste package will experience the majority of its handling operations. The most predictable waste package performance, consistent with current best practice, will be achieved by a waste package containing a wasteform that is 'essentially monolithic'³ and with minimum voidage.

5.1 Physical Immobilisation

The wasteform shall be designed to immobilise radionuclides and toxic materials so as to ensure appropriate waste package performance during all stages of long-term management. For many wastes, this immobilisation requires the use of an encapsulating matrix.

³ Defined, for the purposes of this document, as being a solid mass that would retain its shape if the waste container were removed.

Immobilisation is a process by which mobile fractions of wastes are conditioned in such a way that the potential for migration or dispersion of the radioactivity associated with a waste by natural processes during storage, handling, transport and disposal is reduced.

Adequate immobilisation is the conditioning of waste in such a way that, as a minimum, the release of radionuclides from the packaged waste under normal and accident conditions are within the acceptable range of values defined in the WPS. In the case of radioactive gases, adequate immobilisation will offer an appropriate degree of hold-up and allow controlled and predictable release of the gases at a rate consistent with the acceptable release limits. For liquids (aqueous and non-aqueous) and particulates, movement will be prevented by the wastefrom matrix in which the previously mobile wastes are incorporated.

A particular conditioning feature that can provide benefits in a number areas of wastefrom performance is the use of an inactive grout 'cap'. Usually poured on top of the active wastefrom after it has cured, the grout cap can provide the following benefits to particular conditioned waste types:

- control of the volume of the 'ullage' space between the top of the active wastefrom and the underside of the waste container lid - Section 5.2.2;
- provision of a barrier to the diffusion of gases from the wastefrom and out of the waste package, this is particularly useful in the case of radioactive gases with short half-lives (e.g. radon) - Section 5.5;
- provision of a barrier to the release of loose particulate activity from the upper surface of the active wastefrom - Section 5.1.1;
- improved impact and fire accident performance - Sections 5.1.2 and 5.1.3.

Detailed guidance on the need for and means of achieving effective immobilisation in wastefroms can be found in *Guidance on the Immobilisation of Radionuclides in Wastefroms*, WPS/903.

5.1.1 Immobilisation of Radionuclides and Particulates

All reasonable measures shall be taken to ensure that radionuclides and toxic materials in the waste are immobilised and that loose particulate material is minimised.

Radionuclides can be said to be immobile if the characteristics of fluidity, dispersibility and freedom of movement within the package are eliminated.

The geological disposal of radioactive waste is based on the premise that the radionuclides in the waste will be immobilised within a wastefrom to produce waste packages with minimal loose particulate radioactivity. The selection of inorganic cement-based immobilising matrices has been made by an iterative process which has addressed the need for containment of radioactivity and the persistence of the desired chemical conditions of pH after vault backfilling. This however does not preclude the use of other immobilisation methods such as those involving polymer matrices or immobilisation based on thermal processes such as vitrification.

As the majority of wastefrom requirements in the short term are associated with mechanical, physical and thermal stability, the choice of inorganic cements is partly based on their good properties in these respects. In addition, inorganic cements are:

- inexpensive;
- easy to manufacture and process;
- exhibit good long term stability;

WPS/810/02
March 2008

- have a high tolerance to a wide range of incorporated materials; and,
- tend to minimise the solubility of a number of key radionuclides.

In the longer term, the high pH buffering capacity of most cementitious materials is desirable as they contribute to the pH buffering of a GDF as a whole.

Processes developed to immobilise wastes in waste containers fall into two basic categories:

In-drum mixing where liquid or slurry wastes are mixed with an immobilising material, e.g. dry cement powder, within the waste container drum using a mixing paddle which remains within the wasteform after mixing (the so called 'lost paddle');

In-drum grouting where solid waste items are in-filled within the waste container by the addition of the immobilising material (e.g. cement grout) to infiltrate the waste. This process may include vibration or pressure grouting to aid infiltration between and within small items or those with a geometry that hinders infiltration.

Liquid or slurry wastes need to be sufficiently fluid to allow the cement to be effectively mixed with the waste. The resulting cementitious product should be sufficiently fluid such that the mixing process does not result in regions of un-immobilised waste or voids in the cementitious product. When difficulties are experienced with cement powder incorporation, process development may need to consider the dilution of the waste with water.

Where particulate radionuclides or contamination are present in significant quantities it should be demonstrated that the waste package will meet all particulate radioactivity release requirements of the WPS. Although adequate immobilisation of particulate material or contamination associated with solid waste items can be achieved by in-drum grouting of many wastes, some wastes may contain particulate materials in such quantities and radioactivity content that adequate immobilisation cannot be achieved by simple in-drum grouting. In such cases it may be necessary to separate the particulate material from the solid waste items and use an alternative processing method, e.g. in-drum mixing a slurry of the separated particulate material.

Where radioactivity is present as activation products in large solid items (i.e. not particulates) the radioactivity may be considered to be immobile; however, degradation of such items and the formation of particulate corrosion products needs to be considered.

The in-drum mixing and in-drum grouting processes using cementitious immobilising materials have been shown to provide acceptable product quality and benefits such as minimisation of secondary wastes, ease of processing and low cost. However, other processes may provide similar or specific advantages. Where the use of alternative materials to inorganic cements is being examined, their performance under all conditions which may be encountered and against all performance criteria should be considered. Where the potential use of organic polymeric encapsulants is being considered reference should be made to *Guidance Note on the Use of Organic Polymers for the Encapsulation of ILW, WPS/901*

5.1.2 Response to an Impact Accident

All reasonable measures shall be taken to ensure that, in the event of an impact accident, the quantity of potentially mobile radionuclides present within the waste package, including those generated as a result of the impact accident, is commensurate with the waste package meeting the relevant radioactivity release limits specified in the relevant WPS/300 Series Specification.

The WPS/700 Series documents provide guidance to assist waste packagers in ensuring that waste packages comply with the impact accident performance requirements specified in the relevant WPS/300 Series Specification. The guidance stresses the benefits of

ensuring that radioactivity is well dispersed throughout a solid matrix (see Section 5.2.4) and that areas where radioactivity can remain mobile are minimised. In practice, the most predictable performance will be achieved by a package containing a wasteform that is essentially monolithic.

5.1.3 Response to a Fire Accident

All reasonable measures shall be taken to ensure that, in the event of a fire accident, the quantity of potentially mobile radionuclides present within the waste package, including those generated as a result of the fire accident, is commensurate with the waste package meeting the relevant radioactivity release limits specified in the relevant WPS/300 Series Specification.

In addition, the wasteform should not readily burn or otherwise support combustion.

WPS/700 provides guidance to assist waste packagers in ensuring that waste packages comply with the fire accident performance requirements specified in the relevant WPS/300 Series Specification.

Materials which present a fire hazard should be excluded from the wasteform or made safe (see Section 5.4). Intimate grouting of combustible solids with inorganic cement-based immobilising material would not be expected to result in wasteforms that would burn or otherwise support combustion.

Particular consideration should be given to the treatment of irradiated graphite prior to packaging as this material has the potential to possess significant quantities of stored Wigner energy which could be released in the event of a fire. Guidance on this matter can be found in Reference [7].

5.1.4 Free liquids

All reasonable measures shall be taken to exclude free liquids from the wasteform. This should include materials that may degrade to generate liquids. Free liquids not removed from wastes prior to waste packaging should be immobilised by a suitable waste conditioning process.

A wide variety of liquids may be present as components of wastes or may arise from the processing of wastes into wasteforms. These typically include:

- aqueous solutions such as bleed water, rainwater, pond waters and process liquors;
- organic liquids such as lubricating oils and solvents (e.g. odourless kerosene);
- hydraulic fluids;
- mercury.

The evolution of wasteforms and the degradation of some waste components may also result in the creation of free liquids after waste conditioning.

Free liquids may be defined as those which may drain from the waste package subsequent to a loss of package integrity during an impact or fire accident or by container corrosion. The presence of free liquids implies incomplete immobilisation and such liquids may give rise to a number of undesirable effects within a wasteform including:

- an increase in the mobility of radionuclides or toxic species by solution or suspension;
- an increase the quantity of radioactive material released during normal and accident (e.g. impact and fire) conditions;

- an increase in the potential for chemical interaction between different waste components or between waste components and packaging;
- increased corrosion of the wasteform;
- enhanced microbial activity within the wasteform;
- reduction of the predictability of wasteform performance under normal and accident conditions.

The magnitude of any potentially adverse effect will depend on the nature of the waste and the wasteform and container design. Accordingly, best practice is the complete elimination of free liquids wherever possible. This can be achieved by ensuring that liquids are removed from wastes prior to the encapsulation process, and are not trapped within containers or closed sections; and by the selection of an appropriate conditioning medium to immobilise any liquids that may be present.

The presence of free aqueous liquids may be effectively eliminated by the use of cementitious materials, although the waste may first need to be treated to ensure compatibility with cements (e.g. acids may need to be neutralised), and by packaging processes which separate liquids from wastes. Organic or oily wastes may be immobilised by first sorbing onto a suitable solid followed by immobilisation with a suitable material, providing the other requirements of the specification can be met.

Migration in non-aqueous phase liquids (NAPLs) potentially represents a mechanism for the return of radionuclides from a GDF to the human environment [8]. NAPLs may also be regarded as pollutants in their own right, and pollution of groundwater with such materials may be subject to specific control by regulation. Discharges to groundwater of certain listed substances (which include mineral oils and hydrocarbons) may also be prohibited [9]. If NAPLs are present in the original waste, particular attention should therefore be paid to immobilisation of both the bulk liquids and their radioactive content.

NAPLs are, by definition, immiscible with water and therefore migrate as a separate phase. NAPLs can be either denser (DNAPL) or lighter (LNAPL) than water. LNAPLs in a GDF, being more buoyant than the groundwater, could migrate more directly to the surface, in a similar fashion to gas migration [8]. Furthermore, the non-wetting behaviour of NAPLs would exclude them from the finer pores in the rock mass, so the rate of migration of NAPLs confined to the larger pores and fractures in the geosphere might be significantly greater than that of groundwater. This supposition is supported by experience from the oil industry, for example. If NAPLs were to transport significant quantities of radionuclides from a GDF to the human environment, this more rapid migration would increase radiological risks.

5.2 Mechanical and Physical Properties

The wasteform shall be designed to provide the mechanical and physical properties necessary to ensure appropriate performance of the waste package during all stages of long-term management.

The design and safety assessments for a GDF will be based on the requirement that the waste packages will have the mechanical strength necessary to achieve certain specified standards; inappropriate properties might therefore compromise the basis on which a GDF is designed.

The mechanical and physical properties of the wasteform and the waste container should each be adequate in their own right, and should also be complimentary as much as possible.

As discussed in Section 5.6, progressive evolution and degradation of the wasteform over time is inevitable and this could result in a deterioration of the mechanical and physical

properties of the wasteform. In order that waste packages remain in a condition commensurate with the requirements of the care and maintenance period of a GDF (during which time waste packages are expected to be capable of retrieval in a relatively straightforward manner), properties that could be affected by wasteform evolution should retain acceptable values for a similar period (i.e. up to ~500 years from the date of manufacture of the waste package).

5.2.1 Mechanical Strength

The wasteform shall provide sufficient mechanical strength to allow the waste package to be transported and handled without affecting the ability of the waste package to meet all the requirements of the relevant WPS/300 Series Specification.

The mechanical properties of the wasteform will have a major influence on the response of the waste package to both normal and accident conditions.

Wasteform strength is typically measured as the compressive strength, although that specific property is not necessarily of primary importance to waste package performance. However, it is a useful indicator of the general robustness of the wasteform under static loadings (i.e. such as those experienced during the free stacking of waste packages) and impact accident conditions.

Although the mechanical properties of the waste container are likely to be the determining factor with regard to the ability of the waste package to meet the requirements for stacking, in some cases the wasteform may be required to provide support to the waste container walls to prevent buckling.

Sufficient strength for transport, handling and storage is likely to be achieved using typical cementitious immobilising matrices. WPS/700 gives guidance with regard to the waste package strength commensurate with meeting stacking requirements and the radioactivity release limits for impact accident conditions.

5.2.2 Voidage

The development and production of the wasteform should ensure that the volume of voidage within the waste package (such as ullage, holes or other spaces) is minimised.

Voidage, including macroporosity, consists of discrete non-infilled spaces within the wasteform. Such voidage reduces confidence in the predictability of performance under normal and accident conditions. Furthermore, voidage may undermine steps taken to engineer particular properties of the wasteform or address specific performance criteria. Examples of the possible adverse effects of voidage include:

- local corrosion leading to the presence of mobile particles with a significant radionuclide content;
- prevention or hindrance of the chemical conditioning of key constituents of the waste;
- reduction in wasteform and waste package strength compared with expected values;
- accumulation of flammable/explosive gas;
- generation of other hazardous materials (e.g. metal hydrides);
- long-term slumping/subsidence.

The actual consequences of voidage, in particular the magnitude of any related hazards, will depend on the nature of waste, the wasteform and the container design. Accordingly,

minimisation of voidage is considered to be best practice, building confidence in the packaging process and the predictability of waste package performance.

Voidage within wasteforms can normally be reduced by the use of conventional immobilising materials such as inorganic cements, suitably fluid grouts and efficient mixing/infilling processes. In addition, the waste can be arranged in the container so that infilling of voids can be effectively achieved. For example, voidage may be minimised by placing curved or cupped items into containers with the concave surfaces uppermost. Items with enclosed voids, such as paint tins, pumps and valves, should be opened or punctured and oriented to allow complete grout infiltration. Where loose particulate material is present in voids, special measures may be necessary to ensure adequate immobilisation (see Section 5.1.1).

Some wastes (e.g. filters) present particular challenges in the minimisation of voidage and specific guidance is available in *Guidance Note on the Packaging of Filters, WPS/905*.

The use of non-cementitious matrices, including other inorganic materials and organic polymer-based systems, may also be considered for particularly challenging wastes. With regard to the latter, reference should be made to *Guidance Note on the Use of Organic Polymers for the Encapsulation of Intermediate Level Waste, WPS/901* where candidate polymeric materials are identified and discussed.

5.2.3 Mass-Transport Properties

The wasteform shall be sufficiently permeable to allow gases generated within the wasteform to be released without compromising the ability of the waste package to meet any aspect of the relevant WPS/300 Series Specification.

The mass transport properties of the wasteform (e.g. diffusivity and permeability) shall provide best practicable means for containment of water-soluble radionuclides within the waste package.

The mass-transport properties of the wasteform will influence the performance of the waste package, both directly through an influence on the rate of radionuclide release, and indirectly through an influence on the degradation of the wasteform. Such degradation will influence both the rate of release of radionuclides under normal conditions and the response of the waste package to accident conditions (see Section 5.1).

The permeability of a wasteform to gas is important with regard to its long-term integrity. Gas generation within a wasteform by various mechanisms (see Section 5.5) may pressurise pores and voidage if the wasteform is not sufficiently permeable to release the gas. In extreme cases this may be sufficient to cause degradation of the wasteform if the pressure exceeds the strength of the wasteform and cracking occurs.

However, during interim storage and transport, and the handling operations associated with these periods of the long-term management of waste packages, the release of radionuclides from the wasteform would result in a direct hazard. The elimination or minimisation of such releases is necessary to control the risk to workers and the public, and to conform to the safety cases for transport and the operational period of a GDF.

Part of the rationale for the integrity requirements of the waste container, as discussed in WPS/700, is for the containment of relatively short-lived radionuclides such as Sr-90 and Cs-137, for a sufficient period of time to permit very substantial radioactive decay. The requirement for packages to be vented may be seen as compromising this aspect of container integrity during the early post-closure period of a GDF, and therefore the wasteform is expected to play its part in achieving containment during this period. The mass-transport properties of the wasteform should therefore be engineered to ensure that the potential for the release of these radionuclides is as low as reasonably achievable.

A feature of geological disposal is that in the post-closure period, after a GDF has been re-saturated by groundwater, the permeability of the wasteform to water will no longer be of fundamental importance. This is because further barriers will by then have taken over the main role of long-term containment (i.e. the cementitious backfill, and the location of a GDF in an appropriate hydro-geological environment). However, the performance of a GDF could still be improved to some extent by a low groundwater flow through the wasteform, which would result if the wasteform has a lower hydraulic permeability than the surrounding backfill. A wasteform permeability of down to one-tenth that of the backfill could be advantageous, although no significant benefits are expected below this value [10]. As a guide, the waste packager should seek to achieve a water permeability that is lower than the design permeability of backfill (i.e. lower than 10-16m²). Such values are readily achieved by the use of cement-based immobilising material, provided that good manufacturing practice is followed.

The permeability to water of pulverised fuel ash (PFA)/Ordinary Portland Cement (OPC) blends is generally higher than those of ground granulated blast furnace slag (BFS)/OPC blends. However, a wasteform with a permeability lower than that of the backfill can be readily manufactured with either cement type.

5.2.4 Homogeneity / Uniformity

Local concentrations of materials within the wasteform that may compromise the ability of the waste package to meet any aspect of the relevant WPS/300 Series Specification should be avoided.

Lack of homogeneity in a wasteform may undermine the steps taken to engineer particular properties of the wasteform to address other performance criteria. Heterogeneity may also reduce confidence in the predictability of waste package performance under normal and accident conditions.

Examples of the possible effects of significant heterogeneity include:

- local concentrations of radionuclides that can lead to localised increases in external dose rates;
- local concentrations of radionuclides reducing the predictability of waste package performance under impact and fire accident conditions;
- local concentrations of waste materials which create chemical conditions that could accelerate waste degradation by chemical and microbiological mechanisms.

The actual consequences of excessive heterogeneity, in particular any hazards arising from, or enhanced by, such heterogeneity, will depend on the nature of waste, the wasteform and the container design. To avoid these possibly intractable problems, best practice when processing the waste for packaging is to control operations so that heterogeneity in the wasteform is minimised.

High concentrations of reactive metal content may compromise the mechanical integrity of the wasteform as a result of localised expansion caused by corrosion, which may otherwise not threaten wasteform integrity if the metal was evenly distributed throughout the wasteform.

Localised areas of high activity material within the wasteform may compromise its mechanical integrity due to radiolytic gas generation and high heat generation leading to differential stresses within the wasteform. The latter may be exacerbated by marked variations in thermal conductivity within the wasteform.

Areas containing low-strength materials, such as organic materials, or discontinuities in the wasteform such as cracking or poor bonding planes, may make the package weaker and so more susceptible to damage in the event of an accident.

Lack of homogeneity and uniformity in a wasteform may arise due to the following factors:

- packaging of diverse wastes;
- the presence of hollow or sealed objects;
- the flotation of low-density wastes such as plastics and wood;
- the accumulation of high-density wastes such as metals at the bottom of the container.

Best practise should therefore be adopted to identify the potential for such problems and, to promote homogeneity and uniformity, the following factors should be considered:

- separation of waste types;
- opening/puncturing of hollow or sealed items;
- the use of hold-down apparatus to overcome flotation;
- size reduction of large flat objects;
- placement of hard, sharp items in a controlled fashion within the container to improve impact performance;
- careful wasteform design to prevent cracking.

5.2.5 Thermal Conductivity

The thermal conductivity of the wasteform shall be sufficient to dissipate any heat generated within the waste package, when emplaced in a GDF, without unacceptable temperature rise. The minimum value of thermal conductivity should be $0.5\text{Wm}^{-1}\text{K}^{-1}$.

The effective thermal conductivity of waste packages, governed largely by that of the wasteform, will influence the temperatures they attain during the various periods of their long-term management. In particular, the design of the disposal vaults must take account of the thermal properties of the waste packages, along with those of other engineered features such as the vault lining and the cementitious backfill (when introduced), as well as the thermal properties of the host rock.

A large proportion of the volume of the waste packages, and of the vaults in general, is expected to be occupied by cementitious materials. These materials are expected to exert a major influence on the maximum temperatures that will be attained, and typically have a thermal conductivity in the range $0.5\text{-}0.77\text{Wm}^{-1}\text{K}^{-1}$ [11]. Work to determine the overall thermal conductivity of the backfilled vault [12] for use in post-backfill thermal studies [13] has considered wasteform values in the range $0.5\text{--}5\text{Wm}^{-1}\text{K}^{-1}$. The minimum value is not expected to perturb the overall thermal conductivity of the disposal vaults inappropriately, and should be considered a minimum guidance value for wasteforms.

With regard to an upper limit for wasteform thermal conductivity, work has shown a relative insensitivity of the thermal performance of the backfilled vault to wasteform thermal conductivities in the range $0.5\text{ to }10\text{Wm}^{-1}\text{K}^{-1}$ [12]. However, other features of waste package thermal behaviour, in particular fire performance, may be adversely affected by higher thermal conductivity in the wasteform. Thermal conductivity of the wasteform is an important input parameter for the thermal modelling of packages that is used to predict fire performance [14] as part of the safety assessment process and IAEA guidance on the matter [15] recommends that wasteforms should have 'very low' thermal conductivity for the best fire performance. whilst also acknowledging the necessity for a sufficiently high thermal conductivity to ensure acceptable thermal performance in a GDF as a whole.

Several methods are available for determining the thermal conductivity of a wasteform [16]. Steady-state methods are suitable for measuring the thermal conductivity of cemented

wasteforms over a range of temperatures representative of those expected in a GDF. The type and composition of each waste needs to be considered in order to define the most appropriate method. For heterogeneous wasteforms, small-scale experiments may not be suitable as they may not be large enough to eliminate any anisotropic heat conduction effects that could be created by the presence of large waste items.

For homogeneous wasteforms, including ion exchange resin wasteforms, simple small-scale experimental methods can be used, these methods are described in [17]. Although other methods of determining thermal conductivity are available they are considered to be insufficiently accurate and reproducible.

Inorganic cement typically has a thermal conductivity of about $0.7\text{Wm}^{-1}\text{K}^{-1}$. Consequently, a wasteform containing metal or graphite wastes will have a thermal conductivity above the minimum guidance value. Table 1 lists typical thermal conductivities for a range of cements and cemented wastes.

Table 1 Thermal Conductivities of Typical Wasteforms

Wasteform		Thermal conductivity ($\text{Wm}^{-1}\text{K}^{-1}$)
Cements	BFS/OPC	0.7
	PFA/OPC	0.7
Typical wasteforms	Inorganic Sludge	0.5
	Metal Hydroxide Floc	0.6
	SS Fuel Hulls	1.5
	Graphite Pieces	10.7

5.3 Chemical Containment

The wasteform shall not be incompatible with the chemical containment of radionuclides and hazardous materials as embodied in the requirements of a GDF.

Where they may affect chemical containment, the following items should not be introduced through waste conditioning or packaging, and their presence in wastes should be minimised wherever practicable:

- *Oxidising agents;*
- *Acids and/or materials that degrade to generate acids;*
- *Cellulose and other organic materials;*
- *Complexants and chelating agents, and/or materials that degrade to generate such compounds;*
- *Non Aqueous Phase Liquids (NAPLs) and/or materials that degrade to generate them;*
- *Any other materials that could detrimentally affect chemical containment.*

The near-field chemical barrier in a GDF is provided by the disposal vault backfill which will be formulated to limit the migration of radionuclides over long periods of time [18]. The

backfill is designed to create and sustain an alkaline environment in which the solubility of many key radionuclides will be reduced and the corrosion rates of steels will be minimised. It is porous, presenting a large surface area to increase the sorption of many radionuclides. The backfill has also been designed to allow dispersal of any gas generated within the disposal vaults without causing over-pressurisation.

The long-term performance of a GDF relies on the backfill fulfilling its design functions. The objective in designing and engineering the wasteform is to avoid degrading the effectiveness of the backfill, and to avoid any requirement for an increased quantity of backfill material to be provided. Given the materials already present in the original waste, best practice in the wasteform is wherever practicable to use only materials and processes that contribute to achieving these objectives, and do not create additional problems of their own.

A wasteform may influence the performance of the backfill in several ways, which include:

- increasing the effective solubility of radionuclides, or reducing their sorption, through complexation by materials present in the waste or generated by the degradation of the waste and wasteform [19];
- modifying the chemical conditioning capacity of the backfill through reactions with the materials used for waste immobilisation and packaging, or their degradation products;
- modifying the chemical conditioning capacity of the backfill through reactions with the waste or its degradation products.

The requirement to minimise the presence of organic materials in wasteforms should not be taken to automatically preclude the use of organic polymer encapsulants as an alternative to cementitious grouts. The effects of the use of such materials for specific waste packaging proposals would be assessed by RWMD. RWMD has produced *Guidance Note on the use of Organic Polymers for the Encapsulation of ILW*, WPS/901 and will continue to research the implications of the potential use of such materials and other processes that would produce wasteforms with the required properties (i.e. thermal processes such as vitrification).

5.3.1 Immobilising material chemical containment

For many radionuclides, including several with long half-lives from the transition metal, lanthanide and actinide series, solubility at high pH is low and sorption to cementitious materials is high [20]. This forms the basis for restricting the rate at which radioactivity can migrate from the near-field. It is desirable that conditions of high pH persist for as long as possible to take advantage of these benefits. The waste packager should aim to design a wasteform which does not compromise the ability of the backfill to provide a high pH environment and, if a wasteform contains long-lived radionuclides, is able to contribute to the maintenance of high pH buffering within the package.

The use of inorganic cement based immobilising matrices is the preferred method for maintaining conditions of high pH within a wasteform. Inorganic cements based on BFS/OPC and PFA/OPC formulations are compatible with performance requirements of the backfill. These types of cement will also provide high internal pH buffering. The critical factor controlling the pH generated by inorganic cements is the calcium to silicon atomic ratio (Ca/Si) of the overall cementitious composition of the disposal vaults.

The use of cementitious immobilising matrices with low Ca/Si ratio, beyond the values anticipated by RWMD, may require reappraisal of the quantity of backfill material to be used in a GDF. Therefore, waste packagers are encouraged to use a cementitious immobilising material with a high Ca/Si ratio wherever feasible. The minimum acceptable

effective Ca/Si ratio of the wasteform is dependent upon the waste type and radionuclide content and is considered on a case-by-case basis by RWMD.

5.3.2 Modification of pH buffering by wastes and other materials

Waste materials may modify the ability of backfill to buffer a high pH. For example, commonly encountered organic materials can degrade into acidic species. In judging the effect of these wastes on the buffering behaviour of the local backfill, the effective reduction in the quantity of calcium available for high pH buffering should be assumed to be:

- 18.5 moles of Ca per kg of cellulosic material (wood, cotton, etc.)
- 24.0 moles of Ca per kg of non-cellulosic organic materials (PVC, polythene, perspex, PTFE, etc.)

Waste components with potentially reactive silicon content may also reduce the pH buffering capacity within wasteforms and the surrounding backfill by reaction with calcium and reducing the overall Ca/Si ratio to unacceptably low values. Examples of such materials are zeolites and diatomaceous earths. The potentially reactive silicon content of the waste should be included in consideration of the effective Ca/Si ratio of the wasteform.

Other chemical processes and acidic materials which may significantly affect the nature of the cement phases present in the backfill should also be considered in terms of the effective Ca/Si ratio of the wasteform.

The organic and inorganic material content of the wasteform will be taken into account in assessing the acceptability of the wasteform for disposal.

5.3.3 Complexation of radionuclides

Organic materials present in a wasteform may have a significant effect on the post-closure migration of radionuclides from a GDF. It would be impractical to eliminate organic wastes from a GDF but, wherever practicable, known complexing agents (e.g. EDTA, oxalic and citric acids) should be eliminated from the waste because of their ability to increase the solubility of some long-lived radionuclides. The implications of any complexants in the wasteform will need to be considered by RWMD. Organic materials that are not complexants may have an indirect effect on radionuclide retention within a GDF as their breakdown products may act as complexants. The presence of inorganic complexants should also be considered.

The following is a summary of current understanding of the effect of organic materials, present in the waste or as additives to the wasteform, on radionuclide complexation, although further information is expected as research continues.

a) Cellulose materials

Typical materials in this category are paper, wood and cotton. These can degrade by alkaline hydrolysis to soluble species which will enhance the solubility of key radionuclides. The effect has been found to be greater under anaerobic than aerobic conditions. It has also been found that, for a homogeneous system, the effect is strongly dependent on the loading of organic materials. Wasteforms containing such materials will therefore need to be assessed on a case-by-case basis by RWMD.

b) Condensation polymers

Typical materials in this category are some ion-exchange resins (e.g. phenol formaldehyde based polymers), nylon or alternative immobilising matrices (e.g. epoxy resins). When degraded under anaerobic conditions, these polymers have an insignificant impact on the solubility of key radionuclides. However, under aerobic conditions, such as are expected to exist within vented waste containers and for a period after emplacement in a GDF, degradation of these polymers has been shown to increase the solubility of key

radionuclides. RWMD will assess wastes containing condensation polymers on a case by case basis. However, it is currently considered to be an advantage if a reducing environment develops within the wasteform.

c) Addition polymers

Typical materials in this category are some ion-exchange resins (e.g. polystyrene-divinyl benzene based polymers) and saturated hydrocarbon-based polymers such as polythene and PVC. Addition polymers and their degradation products have been shown by experiment to have little or no effect on the solubility of key radionuclides. Accordingly, a wasteform content limit arising from complexant formation is not envisaged for these materials.

d) Additives in grouts

It is recognised that cement additives may prove acceptable within specified dosage and formulation restrictions but waste packagers should seek advice from RWMD when considering their use.

5.4 Hazardous Materials

The wasteform shall not contain hazardous⁴ materials, or have the potential to generate such materials, unless the treatment and packaging of such materials or items makes them safe. The means by which any of these materials is made safe shall be demonstrable for all relevant periods of long-term management.

Radioactive wastes contain a wide variety of materials, some of which, because of their chemical and/or physical nature, create additional hazards during packaging, transportation and disposal. The elimination of such materials from waste packages, or their treatment to render them less hazardous, is therefore an important factor in ensuring the passive safety of waste packages.

Such materials may exist at the time of packaging, and further hazardous materials (e.g. organic molecules and gases) may be produced from the degradation of the waste or of the materials used for conditioning and packaging, and/or by reactions between them. The transport and handling of all such materials will be subject to the appropriate regulations as well as a general duty of care. Consequently, the potential presence or generation of such hazardous materials must be taken into account during the design of waste packages.

5.4.1 General Considerations

The nature and magnitude of the hazard will depend on the nature of the waste, wasteform and packaging methods. During the development of the waste package, the waste packager should demonstrate that these materials have been considered, and that they will be neutralised or removed. Hazardous materials may include pyrophoric or explosive materials, in which case it will be necessary to demonstrate that such materials have been rendered safe; more specifically, it will be necessary to demonstrate that the resulting waste package will meet the requirements of transport and operational safety cases. Some objects contained in wastes may constitute a hazard because of their physical state, as distinct from a chemical hazard. Examples of this category of hazardous material are wastes that include pressurised and/or sealed containers. Elimination or treatment of such items is necessary to ensure a safe and stable wasteform.

⁴ Including flammable, explosive, pyrophoric, chemo-toxic and oxidising materials; sealed and/or pressurised containers; and/or mechanical devices containing stored energy.

The following sub-sections discuss specific types of hazardous materials in more detail. It should be remembered that some waste materials involve more than one type of hazard.

5.4.2 Pyrophoric Materials

Pyrophoric materials are materials that are liable to combust or oxidise rapidly when exposed to air. They are typically metals, or mixture of metals with their oxides, in a finely divided form. Particular examples are finely divided uranium, thorium and plutonium metal, other examples include uranium hydride and phosphorus.

The presence of pyrophoric materials in a waste package presents an increased fire hazard by providing a potential ignition source for combustible waste and increases the possibility of sustained combustion. They also provide a potential source of ignition for flammable gases such as hydrogen which, under certain conditions, may be generated within the wasteform.

5.4.3 Oxidising Materials

Oxidising materials are defined as those which exhibit highly exothermic reactions when in contact with other substances, particularly flammable substances.

The presence of oxidising materials increases the potential for fire, as they provide a source of oxygen to combustible material. The presence of both types of material in the same waste may therefore compromise the benefits of a conditioning process that seeks to render the waste non-combustible by excluding atmospheric oxygen. Examples of oxidising materials include peroxides, chlorates and nitrates.

5.4.4 Flammable Liquids and Gases

Flammability hazards are subdivided into 'highly flammable' and 'flammable'. Highly flammable materials include:

- liquids having a flash point below 21°C (which may therefore catch fire at ambient temperature);
- gaseous substances that are flammable in air at room temperature;
- substances which in contact with damp air or water evolve highly flammable gases in dangerous quantities.
- Flammable substances are defined as liquid substances or preparations with a flashpoint $\geq 21^{\circ}\text{C}$ and $\leq 55^{\circ}\text{C}$.

Flammable gases can arise from several sources. The main gas will be hydrogen, generated by the radiolysis of water and organic material, by the reaction of metals such as aluminium, magnesium and zinc with cement grout and/or by the reaction of hydrides with water that is free or bound within the wasteform. Carbides present in wastes may react with free or bound water to generate acetylene, methane and ethane. Methane may also be generated from anaerobic microbial degradation of organic material, particularly putrescible material.

Although the exclusion of free liquids from a waste package is required within the wasteform specifications, the presence of sorbed flammable liquids such as flammable solvents could present an increased fire hazard.

5.4.5 Explosive Materials

Explosive materials are defined as those which may explode under the effect of flame or which are more sensitive to shocks or friction than dinitrobenzene.

The potential for explosions and explosive dispersal of material from a waste package during surface storage and handling and transport represents a risk of injury and/or

increased doses to workers and the public, and may cause damage to plant, safety systems and other waste packages.

The assessment of any explosion hazard must take account of situations where combinations of substances within a waste have the potential to generate explosive materials. An extreme example of this would be the combination of ammonium nitrate with a fuel source.

Examples of explosive materials that may be present in wastes include boron hydrides and lead azide.

5.4.6 Sealed and/or Pressurised Containers

The presence of sealed and/or pressurised containers within a wasteform would represent a significant increase in risk of damage to the wasteform and breaching of the waste package. Typical examples of pressurised containers are gas cylinders, aerosol cans, components of compressed air systems and reservoirs.

Release of the stored energy by catastrophic⁵ failure of a pressurised container could result in breaching of the package and airborne dispersal of the package contents. During the storage, handling and transport operations this would represent a risk from injury, increased dose to workers, and possible damage to safety systems and other packages. Less energetic failures could result in localised damage to the wasteform and an associated loss of integrity. Additional hazards could also be presented by the released contents of the container if they are hazardous in their own right. Sealed containers that were not pressurised at the time of packaging could nonetheless become pressurised as a result of gas generation due to corrosion, radioactive decay (e.g. of radium to form radon) and/or radiolysis. The presence of sealed containers in wasteforms could also compromise the requirement to minimise voidage (Section 5.2.2).

5.5 Gas Generation

Gases generated by the wasteform shall not compromise the ability of the waste package to meet any aspect of the relevant WPS/300 Series Specification.

Gases may be generated in wasteforms by a variety of processes, including:

- chemical processes such as corrosion;
- microbial degradation of organic materials;
- radiolysis of water and organic materials;
- radioactive decay producing gaseous species (e.g. radon).

Gases such as H₂O, H₂, CO₂ and CH₄ may be generated in significant quantities within wasteforms by the first three processes. Each of these species may include radioactive isotopes H-3 and/or C-14. Bulk gas releases may also entrain any smaller quantities of other radioactive species such as Rn-220, Rn-222, Ar-41 and/or Kr-85 which may be present.

Gas generation by the mechanisms of corrosion, degradation of organic materials and by radiolysis (including an assessment of radioactive gas generation) is considered in the

⁵ 'Catastrophic' is used here in the strictly limited technical sense that the release event occurs suddenly; it does not carry any implications about the consequences.

sections below. Generation of non-radioactive gas by radioactive decay (e.g. helium from α -decay) is not considered to be significant for most ILW.

In practice, gas generation by corrosion and degradation of cellulose and other organic materials yield higher rates than gas generation by radiolysis but the latter should not be ignored. The principal gases (in volume terms) are H₂, CO₂, CH₄ and H₂S.

Gases give rise to a range of potential effects that may have an influence on all periods of the long-term management of waste packages. Excessive gas generation may lead to pressurisation and damage of the wasteform, leading to:

- a waste/cement interface with significant localised voids giving poor bonding and a weak wasteform;
- gas channelling through to the surface of the wasteform resulting in poor immobilisation of particulate radioactivity;
- a friable grout layer at the wasteform surface giving rise to increased levels of respirable particulates which could be released under normal and accident conditions.

During the waste packaging process, gas generation may also have a number of effects. Initially these will be process considerations, for example explosion/flammability safety and toxicity. However, gas generation at this initial stage of production may significantly modify the desired properties of a wasteform or compromise the packaging concept. Gas generation may be minimised during the production of a wasteform by reducing the rate of corrosion by careful selection of the wasteform cement, the use of a corrosion inhibitor or by limiting the content of gas-generating materials.

The rate of gas generation which can be sustained without such degradation of a wasteform will be controlled by a number of factors. These include:

- the geometry and size of the wasteform;
- the composition of the wasteform;
- the permeability of the wasteform to the gases generated;
- the tensile strength of the wasteform, including the presence of internal defects resulting from the production process;
- the uniformity of gas generation.

The limits placed by transport on the generation of different types of gas by waste packages is dealt with in the WPS/700 Series documents and summarised in Table 2. Two sets of values are given for the 3 cubic metre Box waste package depending on whether the dimensions of the waste container are at the maximum⁶ or the minimum⁷ permitted by WPS/315.

⁶ Assumed to be a 3 cubic metre Box with plan dimensions of 1720 x 1720mm

⁷ Assumed to be a 3 cubic metre Box with plan dimensions of 1665 x 1665mm

Table 2 Gas generation limits set by transport

Type of Gas	Basis for Limit		Gas Generation Limit		
			3 Cubic metre Box		3 cubic metre Drum
			Maximum Dimensions	Minimum Dimensions	
Total gas generation (litres/day)	Maintaining transport container cavity pressure below MNOP during transport period		72	101	228
Specific gases (litres/day)	Concentration <75% LFL during transport period	Hydrogen	0.43	0.61	1.38
		Methane	0.61	0.85	1.95
		Hydrogen Sulphide	0.46	0.64	1.48
	Concentration <4% during transport period	Oxygen	0.24	0.34	0.79
Radioactive Gases (A ₂ /day)	Limit release from transport container to 10 ⁻⁶ A ₂ /hour	Tritium	1.13x10 ⁻⁴	1.58x10 ⁻⁴	3.60x10 ⁻⁴
		Others	4.30x10 ⁻⁴	6.00x10 ⁻⁴	1.37x10 ⁻³

5.5.1 Gas generation by corrosion

The rate of hydrogen generated by corrosion under anaerobic conditions can be estimated from the equation:

$$V = 6.14 \times 10^{-6} r A \rho S / M$$

Where V is the volume of hydrogen gas generated in litres/day, r is the corrosion rate in µm/yr, A is the corroding area in m², ρ is the density of the metal in kgm⁻³, M is the atomic weight of the metal in g and S is the stoichiometry of the reaction⁸. Table 3 lists simplified versions of this equation from which estimates of hydrogen generation may be determined using representative values for r and A.

⁸ i.e. the number of moles of hydrogen generated by the corrosion of 1 mole of metal.

Table 3 Gas generation rates of selected metals by corrosion

Metal	Gas Generation Rate (litres/day)
Aluminium	9.2×10^{-3} rA
Magnesium	4.4×10^{-3} rA
Mild Steel	8.6×10^{-3} rA
Uranium	9.9×10^{-3} rA

Options to minimise metal corrosion in packaged waste are considered in Section 5.6.2.

5.5.2 Gas generation by radiolysis

The rate of gas generation by the radiolysis of water can be estimated from:

$$V = 0.22 \text{ GQ litres/day}$$

where Q is the heat output in watts for the volume of wasteform in question and G is the G-value (experimentally determined value expressed in molecules produced per 100eV of energy absorbed) for each gas.

The G-values vary somewhat for α -particles and γ -rays and also between materials. For the OPC/BFS or OPC/PFA cements studied to date only hydrogen gas is generated in significant quantities and a typical $G(\text{H}_2)$ value is about 0.1. This value may vary, depending on the waste type and loading and the water content of the wasteform. On this basis, the restrictions on the heat output of wasteforms will limit the gas output to well below the level at which damage might occur for standard cemented wasteforms. However, further consideration may be required if gas may be generated from radiolysis of other materials in the waste (e.g. plastics and rubbers).

Where other gases will be generated experimental values analogous to the $G(\text{H}_2)$ values may be used to calculate gas generation e.g. $G(\text{O}_2)$, $G(\text{HCl})$, $G(\text{CO}_2)$ etc.

5.5.3 Gas generation by degradation of cellulose and other organic materials

Biodegradation of cellulosic material may give rise to the production of CO_2 and CH_4 . Although the estimated volume of gas that would be generated by cellulose intimately cemented in a wasteform is very small if such waste was not in intimate contact with the cement, gas generation rates may reach several tens of litres per day from microbial activity alone under specific conditions. It is therefore important that organic components of the waste are well immobilised within the cement or that adequate account is taken of the likely rate of generation of gases.

5.5.4 Radioactive gas generation

Some metallic wastes (e.g. fuel cladding) contain tritium, either combined as metal tritides, or in the form of tritiated hydrogen which has diffused into the metal surface. These are usually 'hard' wastes (i.e. diffusionally thick solids) which have been tritiated at above-ambient temperatures for extended periods of time. For tritium in these forms, the release rate is dependent on the corrosion rate and/or the rate of diffusion of tritium from the material.

Tritium is also present in wastes as tritiated water; most usually in 'soft' laboratory-type wastes which are predominantly papers, tissues and other diffusionally thin materials. Tritiated water may become involved in corrosion processes and thus be converted to tritiated hydrogen or released by evaporation. Thus, the corrosion rate is important, together with the ratio of tritiated water to normal water associated with wastes, and the accessibility of corrosion sites to tritiated water. Tritium-labelled methane and hydrogen sulphide may also be formed from microbial action on organic materials if tritiated hydrogen or tritiated water become involved in the reactions. Guidance on this issue can be found in *Guidance Note on the Packaging of Tritium-bearing Wastes, WPS/907*.

Many radionuclides can be incorporated into other gaseous molecules by microbial action. Methane and carbon dioxide labelled with C-14 are the principal gases expected from this source; however, radioactively labelled H₂S may be generated under anaerobic conditions. The ratio of stable nuclide to radioisotope (e.g. organic C-14 to C-12) is important in determining the extent of generation of the radioactive gas, taking into account the chemical form of the radioactive material and isotopic exchange.

Owing to their relatively long half-lives (12.3 years for tritium and 5,730 years for C-14) it is unlikely that hold-up offered by transport through a porous wastefrom would offer sufficient decay to significantly reduce releases of these two radionuclides in gaseous forms prior to disposal unless sufficient isotopic exchange occurred. However, reductions in the generation rates for their inactive analogues would lead to corresponding reductions in radioactivity releases.

Some wastes produce radioactive gases by decay, notably radon isotopes from actinide decay. Radon occurs naturally in the decay series of Th-232 and U-238, resulting in Rn-220 and Rn-222 respectively. In addition, concentrated sources of U-232 and Ra-226, producing Rn-220 and Rn-222 respectively, may be present in some wastes.

The half-lives of Rn-220 and Rn-222 are relatively short (i.e. 55.6 seconds and 3.82 days respectively) and discharges of radon from waste packages can therefore be significantly reduced by wastefroms that provide containment and/or hold-up to permit decay within the waste package, thus retaining the decay products within the waste package. Guidance on this issue can be found in *Guidance Note on the Packaging of Radon Generating Wastes, WPS/902*.

5.6 Wastefrom Evolution

Changes in the characteristics of the wastefrom as it evolves shall not result in degradation that will compromise the ability of the waste package to meet any aspect of the relevant WPS/300 Series Specification.

The deleterious effects of the following processes should be considered:

- ***dimensional changes, e.g. shrinkage;***
- ***corrosion including, but not limited to, the production of gases and particulate material, and wastefrom expansion resulting from the formation of lower density solid corrosion products;***
- ***microbial activity;***
- ***self-irradiation and irradiation by surrounding waste packages;***
- ***heat generation by the wastefrom and its surroundings including, but not limited to, localised heat sources within the wastefrom, the effects on the curing of the encapsulant material and the consequential effects on longer-term performance.***

Although progressive evolution and degradation of the wasteform is inevitable, wasteform stability and predictability of degradation over an extended period benefits development of safety cases for all periods of the long-term management of waste packages.

Potentially, many of the aspects of wasteform and waste package performance dealt with in the Specification could be compromised by excessive degradation of the wasteform. Those aspects that are particularly susceptible are;

- immobilisation of radionuclides and other hazardous materials;
- container dimensions and shape;
- impact and fire accident performance;
- wasteform mechanical strength;
- wasteform voidage;
- gas generation.

The following sub-sections discuss specific topics related to wasteform evolution and degradation.

5.6.1 Dimensional Stability

Wasteforms will be subject to physical or chemical processes that may result in dimensional changes. Dimensional changes may ultimately lead to a reduction in the containment offered by the wasteform, either by causing degradation of the wasteform itself (most commonly, cracking) or by rendering the wasteform more susceptible to other degradation processes (e.g. shrinkage could result in the creation of voids). The wasteform should therefore be designed to minimise the potential for dimensional changes, and to minimise the extent and rate of such changes as might occur.

Hydration of OPC systems involves the reaction of a range of calcium silicate and calcium aluminate phases with water. The hydration process is usually associated with volume changes, particularly at early age when hydration is most vigorous. Reaction and volume change may continue for a considerable time, albeit at a very slow rate, involving continued hydration and also reaction between the cement and waste components. The exchange of water between the hydrated cement phases and the surrounding pore structure may also result in volume changes. These processes mean that a wasteform is continually evolving over its functional lifetime, both chemically and physically.

The degree of shrinkage or expansion which may be accommodated by a wasteform before degradation occurs will be related to the strength, the geometry and size of the wasteform, solid materials contained within the wasteform (such as large items of solid waste or a mixing paddle) and the rate and uniformity of any dimensional changes within the wasteform. For homogeneous cementitious wasteforms of compressive strengths up to 40MPa, it has been observed [i.e. 21] that shrinkages measured in the laboratory of less than 2,000 micro-strain (ppm) after 1 year do not result in cracking of a wasteform that would make it fail to meet the immobilisation and mass-transport requirements of the specification (Sections 5.1.1 and 5.2.3). However, it is recognised that larger movements may be accommodated by a wasteform, depending upon the factors described above, and this does not, therefore, constitute a limit.

Examples of waste types that have strong interactions with inorganic cements are soluble sulphates, nitrates and silicates. Many or all of these interactions may be controlled by judicious selection of the immobilising material and waste loading. However, in practice, experimental validation of cement/waste systems is required to justify a particular formulation.

Water movement may result from competition for water within the cement wasteform, or the loss or addition of water to the wasteform as a whole. The nature of the changes that take place will depend on the composition of the wasteform and on external factors such as temperature and relative humidity. The most important of these effects is likely to be drying which will result in shrinkage. The presence of a capping layer on the wasteform will significantly reduce drying of the wasteform and protect it from drying shrinkage.

Where dimensional movements caused by waste/cement interactions or water movement cause wasteform degradation, the stability of the wasteform may be improved by chemical conversion of reactive waste components, dilution of reactive waste components to tolerable concentrations, selection of alternative immobilising matrices or by the use of fibre reinforcement so that although the wasteform may still experience cracking, it can retain its overall integrity for handling purposes. It should be noted, however, that the use of alternative materials or techniques to improve dimensional stability may impact on other wasteform and/or waste package characteristics and would have to be assessed fully before they could be endorsed.

5.6.2 Corrosion

Most metals will corrode under the moist alkaline conditions inherent to the cement matrices preferred for the immobilisation of waste, although the rate and mechanism of corrosion will vary between different materials under differing conditions. Magnesium, aluminium and uranium are examples of metals present in waste whose corrosion performance under alkaline conditions may significantly affect package performance.

Corrosion of wasteforms could result in the degradation of a previously solid wasteform into one that would no longer effectively immobilise the radionuclides or other hazardous materials. For example, larger pieces of metal may be degraded into powdery corrosion products and this could have significant consequences for the fire and impact performance of the waste package.

The products of corrosion are typically less dense than the source material, which results in a net increase in waste volume. This expansion places strain upon the encapsulating matrix, and cracking or other forms of disruption may ultimately reduce the containment offered by the waste package.

Metal corrosion also often results in the generation of heat and gas. The generation of heat by corrosion is considered in Section 5.6.4 and the generation of gas by corrosion was considered in Section 5.5.1.

The potential for wasteform degradation will be dependent on many factors:

- the corroding metal;
- the mechanism of corrosion;
- the geometry of the waste;
- the rate of corrosion;
- the strain capacity and creep characteristics of the immobilising material;
- the storage conditions which the wasteform will encounter.

The wasteform should minimise the rate of corrosion or control the consequences of corrosion to ensure appropriate radionuclide immobilisation. Metal corrosion, for example, occurs when a sufficient source of water is available, and its rate typically varies according to oxygen concentration. Corrosion may therefore be controlled by eliminating or minimising the quantities of the reactants required, i.e. metal, water and oxygen, and/or by limiting the contact of such reactants.

The rate of corrosion of the metal will depend on the availability of water, temperature, the composition of the contacting aqueous phase, the presence of dissimilar metals (bi-metallic or galvanic corrosion) and the presence of any passivating surface film. Chloride and thiosulphate ions, for example, are known to accelerate the corrosion of steels and Magnox, while the pH of the system will influence the corrosion of metal components in general.

The quantity and form of some metallic wastes within a wasteform, and corrosion accelerating materials in wastes and immobilising materials, may need to be controlled in order to provide adequate performance under conditions that will be encountered. It is recommended that wasteforms which generate a high pH are used for mild and stainless steels, encouraging passive corrosion. More reactive metals such as Magnox and aluminium may need to have limits imposed on their wasteform loadings.

Several general options are available to reduce or minimise metal corrosion in packaged waste, including:

- careful formulation of the immobilising material to ensure low availability of moisture, e.g. low water content superplasticised inorganic cements (however see Section 5.3.3);
- incorporation of corrosion inhibitors;
- segregation of dissimilar metals to minimise bi-metallic corrosion;
- minimising the presence of void spaces within which more corrosive conditions may develop, e.g. acid regions from the microbial degradation of poorly immobilised or non-immobilised organic wastes.

5.6.3 Radiation stability

Radiolysis of wasteform components may give rise to new chemical species that react with the waste or immobilising material. Some of these reactions may result in a change in the performance of the wasteform, reducing its contribution to the immobilisation of radionuclides. The effects of irradiation should therefore be considered when the wasteform is being developed.

Wasteforms will experience both self-irradiation and irradiation by surrounding waste packages during interim surface storage and following emplacement. RWMD has commissioned work to quantify the latter but waste packagers will also need to consider the former period when the activity of waste packages, and the associated radiation doses rates, are higher. The RWMD work has shown that the combination of self-irradiation and irradiation by surrounding waste packages, assuming all packages to contain the 'average'⁹ inventory, corresponding to a wasteform heat output of $\sim 1\text{Wm}^{-3}$, results in a gamma absorbed dose rate of 0.56Gyh^{-1} following emplacement in 2040 [22]. This rate declines to $1.9 \times 10^{-3}\text{Gyh}^{-1}$ in the 300 years following emplacement and results in a total dose of $\sim 0.2\text{MGy}$ over that period. The presence of backfill reduces the total dose by $\sim 15\%$. Self-irradiation and irradiation by surrounding waste packages containing activity resulting in the permissible maximum heat output of 50W for a 500 litre Drum waste package leads to wasteform dose rates of 24Gyh^{-1} and doses of up to 10MGy in ~ 300 years.

Radiation can affect wasteforms in three ways:

⁹ Defined by averaging the entire GDF radionuclide inventory over the total volume of conditioned waste.

- radiolysis of waste components;
- radiolysis of the aqueous phase;
- atomic displacement.

Radiolysis of waste components may give rise to chemical species which attack the immobilising material. In particular, radiolysis of waste components may yield explosive, toxic or reactive gaseous or liquid species. A prime example of this is the radiolysis of water to produce hydrogen; the irradiation of PVC may liberate hydrogen chloride, forming hydrochloric acid on dissolution in water. Reactions involving production of aggressive species may lead to increased container corrosion (stainless steel is particularly affected by the presence of chloride ions); and such species may also affect the mechanical and chemical containment properties of the wasteform [23]. In some more extreme cases, the generation of acidic species by radiolysis of certain wasteform components should be accommodated by an appropriate design of the wasteform, for example the use of annular grouted designs, to protect the waste container.

Atomic displacement from normal lattice sites may occur within the immobilising material causing a volume change in both crystalline and non-crystalline solids. This may lead to disruption of the microstructure and ultimately to spallation, cracking and even disintegration of some materials. These atomic displacements result mainly from 'heavy particle' radiation produced by α - and neutron-emitters.

Experience suggests that cementitious wasteforms are robust and not susceptible to excessive degradation under the cumulative radiation exposure that is expected during surface storage and subsequent emplacement in a GDF [23]. Other encapsulants may also be sufficiently robust. In general, cements and concretes, when well formulated, are regarded as having good radiation resistance to γ radiation doses of the order of 100MGy. However, less information is available on the effects of α and β radiation on wasteforms [24]. If the wasteform contains significant quantities of α - or β -emitters, information or reasoned argument to support the radiation stability of the wasteform will be required.

5.6.4 Thermal effects

All radioactive wastes generate heat as a result of the energy released during radioactive decay. In addition, chemical processes (such as corrosion) and microbiological processes occurring within waste packages may also generate heat. Wigner energy stored within irradiated graphite waste will also be a source of heat if conditions lead to the release of this energy.

The effects of the heat generated by waste packages on the various periods of the long-term management of waste packages is dealt with in the GWPS and discussed for the 500 litre Drum waste package in WPS/700. This shows that a mean heat output of 6Wm^{-3} (i.e. $\sim 10\text{W}$ per 3 cubic metre Box or Drum waste package) and an individual waste package limit of $\sim 150\text{W}$ will not result in temperature targets being exceeded in the post-backfilling period.

In addition to overall GDF temperature issues, the effects of localised heating within individual waste packages and its potential for wasteform damage must be considered. Such localised heating could arise from concentrations of activity (e.g. from sealed sources) or reactive chemicals and could lead to differential expansion of the wasteform, enhanced corrosion of metallic wastes, excessive generation of gases or particulates and could ultimately, in extreme circumstances, lead to failure of the wasteform to meet the specification requirements.

Thus the magnitude and effects of temperature variations within a wasteform should be considered during the design stage and, if necessary, options to reduce both high overall and localised heating considered. This could include decay storage of raw wastes prior to

conditioning, the reduction of package waste loading or the mixing of high activity wastes with more innocuous material. Potential sources of heat generation are described below.

a) Radioactive Decay

The total heat generated by radioactive decay within a wasteform can be calculated directly from the radionuclide inventory and a knowledge of the specific heat output (i.e. W/TBq) from each radionuclide. With typical values of specific heat output of a few W/TBq the heat output of ILW is of the order of 1Wm⁻³ and, if distributed evenly throughout a wasteform, would not constitute a problem. Concentrations of some radionuclides may however result in localised heating. Table 4 lists a number of radionuclides typically found in sealed sources together with their specific heat outputs in W/TBq and W/g. RWMD has produced *Guidance Note on the Packaging of Sealed Sources, WPS/906* which discusses the issues raised by the packaging of such items.

Table 4 Radiogenic heat outputs of selected radionuclides

Radionuclide	Specific Radiogenic Heat Output	
	W/TBq	W/g
Co-60	0.4	17
Sr-90	0.2	1.0
Cs-137	0.1	0.3
Ra-226	4.3	0.2
Pu-238	0.9	0.6
Am-241	0.9	0.1
Cm-244	1.0	2.8

b) Corrosion

The heat output from the corrosion of metal wastes, particularly those whose physical form exposes large surface area to reactants such as water, may be significant and can lead to both general and localised temperature increases in wasteforms. The quantity of heat generated by corrosion can be estimated using the equation:

$$Q = 3.17 \times 10^{-8} r A \rho \Delta H / M$$

where Q is in watts, r is the corrosion rate in $\mu\text{m}/\text{yr}$, A is the corroding area in m^2 , ρ is the density of the metal in kgm^{-3} , ΔH the heat of reaction in kJmol^{-1} and M the atomic weight of the metal. Table 5 lists simplified versions of this equation from which estimates of heat output may be determined using representative values for r and A.

Table 5 Heat of Corrosion for Selected Metals

Metal	Heat Output (W)
Magnox	8.0×10^{-4} rA
Aluminium	1.4×10^{-3} rA
Uranium	2.4×10^{-4} rA

As the rates of chemical reactions such as corrosion vary with temperature and local chemical/electrochemical conditions, heat output from corrosion will vary similarly. Due account must therefore be taken of the conditions which will be encountered.

c) Microbiological degradation

Microbial decomposition of organic materials is only significant for cellulose (yielding CO₂ and CH₄). Intimate contact between alkaline cement and organic wastes will tend to minimise microbial activity. Under such circumstances heat generation by this mechanism would be expected to be insignificant.

d) Other chemical reactions

The initial heat generating chemical reaction for any cemented wasteform is the hydration of the immobilising cement, other non-cementitious encapsulating materials also exhibit similar exothermic behaviour on curing. Consideration should be given to the effect of any exotherm on the long-term properties of the wasteform. Other chemical reactions that might proceed rapidly and generate significant amounts of heat should be prevented by making materials safe beforehand.

e) Other physical reactions

The only class of physical process which is considered to give rise to significant quantities of heat is Wigner energy release. This phenomenon is mostly associated with neutron-irradiated graphite wastes from reactor operations but, in principle, may occur for any crystalline material.

Neutron irradiation of graphite within a reactor causes carbon atoms within the graphite lattice to become displaced, resulting in dimensional changes. A large amount of potential energy may be stored within such irradiated graphite and may be released, as Wigner energy, when the graphite experiences particular thermal conditions. The lowest temperature at which a significant release of Wigner energy would occur is considered to be 50°C above the graphite irradiation temperature. In some cases the irradiation temperature will be as low as normal ambient temperatures. Accordingly, significant Wigner energy release could be initiated as a consequence of a transport accident, or even by normal vault temperatures for some wastes.

Depending on the neutron irradiation history and loading of the graphite in a waste package, the effects of Wigner energy release may range from mild heating of the wasteform to significant self-sustaining temperature rise. As a guide, the greatest level of Wigner energy recorded to date is approximately 2,700Jg⁻¹ which, if this were to be released instantaneously, would result in a temperature rise of up to 1,500°C in such pieces of graphite. The potential for such releases from irradiated graphite and other wasteforms under normal and accident conditions should be considered. The potential for such releases within a wasteform may be removed by annealing the graphite, at temperatures greater than those experienced during the irradiation, prior to waste

packaging. Guidance on the packaging of graphite possessing Wigner energy can be found in [7].

5.7 Nuclear Properties

5.7.1 External Dose Rate

The radionuclide content and nature of the wastefrom should ensure that waste package external dose rate limits as specified in the relevant WPS/300 Series Specification are complied with at the time of transport.

Limits are placed on the external dose rates of waste packages to allow for safe transport through the public domain. Although primarily a waste package issue, and dealt with in the WPS/700 Series documents, the wastefrom can play a significant role in the control of external dose rate

It is anticipated that most 3 cubic metre Box and Drum waste packages will be carried through the public domain in shielded transport containers which will provide the necessary radiation shielding. The combination of waste packages and transport container will be transported as Type B transport packages and in accordance with the IAEA Transport Regulations [5]. This will place limits on external dose rate of 2mSvhr^{-1} at the surface and 0.1mSvhr^{-1} at 1m from the surface of a transport package (i.e. a transport container containing waste packages) carried under the conditions of 'non-exclusive use'¹⁰.

Restrictions on the weight and maximum dimensions of the transport container, placed by the UK transport infrastructure, limit the thickness of shielding which can be provided during transport to 280mm of steel. These limits are applied 3 cubic metre Box or Drum waste package when shielded by a 280mm thick steel shield of density $7,700\text{kgm}^{-3}$ (see the relevant WPS/300 Series Specification.). As part of the packaging assessment submission waste packagers should show that packages will not exceed these limits.

The external dose rate of a waste package will be related to:

- the quantity and type of radioactivity contained (taking into account radioactive decay to the time at which transport will take place);
- the degree of self-shielding provided by the wastefrom;
- the distribution of radioactivity within the wastefrom.

The control of the external dose rate from waste packages is directly by control of one or more of these.

In the case of waste packages containing significant quantities of γ -emitting radionuclides (e.g. Co-60 and Cs-137), it is recommended that calculations are made with validated computer codes.

Where waste packagers encounter difficulties in meeting the shielding requirements, several options may be considered. These include:

- storage of wastes prior to transport to gain benefit from radioactive decay;

¹⁰ Exclusive use' is defined by the IAEA Transport Regulations (Paragraph 221) as meaning 'the sole use, by a single consignor, of a conveyance or large freight container, in respect of which all initial, intermediate and final loading and unloading is carried out in accordance with the consignor or consignee'. If all of these conditions cannot be met, transport is deemed to take place under 'non-exclusive use'.

- use of an immobilising material with good shielding properties;
- increasing the shielding provided by the container by increasing wall thickness and/or the use of an annular grouted wasteform;
- reduction of package waste loadings;
- ensuring the uniform distribution of activity throughout the package;
- segregation of high activity items and placing them in the centre of the waste package.
- Whichever method is used to meet the shielding requirements it does not affect other limits for the radionuclide contents of the containers, for example those set by heat output.

5.7.2 Criticality Safety

The presence of fissile materials, neutron moderators and reflectors in the waste package shall be controlled to ensure that they do not present a criticality safety hazard during any of the active stages of their long-term management.

It shall also be ensured that, following closure of a GDF, the possibility of local accumulation of fissile material such as to produce a neutron chain reaction is not a significant concern to the long-term performance of a GDF.

Criticality safety will need to be demonstrated for packages containing fissile materials¹¹ for all periods of the long-term management of waste packages. Waste packages containing quantities of fissile material at or below the generic screening level of 50g of Pu-239 are considered to be benign under all circumstances, but those containing larger quantities will need further consideration. Methodologies exist for the control of package design and contents to ensure that these packages would also be benign from a criticality point of view.

RWMD has developed a methodology for producing Criticality Safety Assessments (CSA) for wastes containing specific fissile materials types. Each CSA considers the criticality safety of waste packages during transport and the operational and post-closure stages of a GDF. The output of such a CSA includes the definition of a Lower Screening Level (LSL) and an Upper Screening Level (USL) based on conservative and more-credible assumptions respectively, with the aim of ensuring that waste package limits for fissile materials are proportionate and not unduly restrictive.

The categories of fissile material considered to date are low enriched uranium (LEU), highly enriched uranium (HEU), plutonium-contaminated material (PCM) and irradiated natural uranium (INU). These four categories were selected so as to be applicable to a large proportion of the wastes in the UK ILW inventory that contain fissile material. For wastes falling outside of these categories a package specific CSAs can be performed or the generic screening level adopted.

Waste packagers are responsible for developing operating arrangements consistent with the appropriate assessment and for providing objective evidence in the form of criticality compliance assurance documentation (CCAD). The CCAD must demonstrate how fissile material will be controlled to meet levels defined in the relevant CSA. Information on the structure and the content of CCAD may be found in *Guidance on the Preparation of Criticality Compliance Assurance Documentation for Waste Packaging Proposals*, WPS/625.

¹¹ Defined as U-233, U-235, Pu-239 and Pu-241.

6 GUIDANCE QUANTITIES FOR WASTEFORM CONTENTS

This Section presents, for guidance purposes, information on the material contents of wasteforms for 3 cubic metre Box and Drum waste packages. The contents have been assessed in relation to wasteform and overall GDF performance requirements using best available knowledge for typical in-drum mixed or in-drum grouted wasteforms formulated with BFS/OPC or PFA/OPC inorganic cements. Also included is an indication of the basis of the guidance; i.e. individual wasteform or overall GDF performance. In some cases, only very general guidance can be given due to the generic nature of the specifications. The guidance values are not 'target' or 'limiting' values but are intended to allow waste packagers to gauge the significance of waste composition and variability on wasteform performance. The information is to be considered as purely advisory as wasteform performance may vary significantly with differing immobilising media and waste compositions.

Wasteform Component	Guidance Values	Reason/Comment	Relevant Performance Requirements
Key radionuclides	Threshold Recording Levels and limiting concentration have been determined for all radionuclides of significance [25]	All periods of long-term management.	Immobilisation of radionuclides Mechanical and physical properties:
	Particular examples of guidance values for individual radionuclides per package are:	Values relevant to individual package and overall GDF performance. Other values may arise from site-specific considerations.	Homogeneity/uniformity Chemical containment Wasteform evolution: Radiation stability
	50 TBq Co-60	Transport external dose rate.	Thermal effects Gas generation
	1320 TBq Sr-90	Radiogenic decay heat 200W	Gas generation by radiolysis
	1880 TBq Cs-137	Radiogenic decay heat 200W	Radioactive gas generation
	0.11 TBq Pu-239	50g Generic Screening Level.	Nuclear properties: External dose rate Criticality Safety

Wasteform Component	Guidance Values	Reason/Comment	Relevant Performance Requirements
Soluble and mobile radionuclides	Determined by BPM for containment of soluble, mobile radionuclides whereby the required lifetime of the container is matched to the soluble short-lived radionuclide content of the package (WPS/700).	<p>Containment - demonstration of BPM.</p> <p>Containment of soluble, mobile radionuclides will be relevant to individual package and overall GDF performance.</p>	<p>Immobilisation of radionuclides:</p> <p>Response to an impact accident</p> <p>Response to a fire accident</p> <p>Free liquids</p> <p>Mechanical and physical properties:</p> <p>Mass transport properties</p>
Particulate radioactivity	There are no guidance values on wasteform particulate radioactivity content under normal conditions of transport, handling, storage and disposal as this will be determined by the detailed drum design (i.e. venting and filtration). However, all reasonable measures should be taken to ensure particulate radioactivity content is minimised. Wasteforms with the following particle radioactivity content will fully comply with the waste package specification without needing to guarantee containment under impact and fire accident conditions	Individual package response to transport and handling accidents.	<p>Immobilisation of radionuclides:</p> <p>Immobilisation of radionuclides and particulates</p> <p>Response to impact accident</p> <p>Response to fire accident</p> <p>Mechanical and physical properties:</p> <p>Voidage</p> <p>Mass transport properties</p> <p>Homogeneity/uniformity</p>
	<p>Release of activity in form of particles <40µm following impact resulting from a 10m drop:</p> <p>3 cubic metre Box: Maximum dimensions: 3A₂</p> <p>Minimum dimensions: 5A₂</p>	Activity release from transport container under accident conditions shall not exceed 1A ₂ in week following accident (IAEA Transport Regulations)_	Degradation processes and wasteform stability

Wasteform Component	Guidance Values	Reason/Comment	Relevant Performance Requirements
	<p>3 cubic metre Drum: 11A₂</p> <hr/> <p>Release of activity in form of particles <100µm following impact from a 15m drop (for typical radionuclides):</p> <p>Co-60 1.7x10⁻¹TBq Cs-137 7.4x10⁻¹TBq Pu-239 1.1x10⁻⁴TBq</p> <hr/> <p>Release of activity in all forms following a fire with a flame temperature of 1000°C and a duration of 1 hour (for typical radionuclides):</p> <p>Co-60 3.3TBq Cs-137 16TBq Pu-239 2.3x10⁻³TBq</p>	<p>Activity release under GDF accident conditions should not exceed NII SAPs BSLs for DBA with frequency of >10⁻³ pa.</p>	
Fissile radionuclides	50g of Pu-239 or equivalent	<p>Criticality safety.</p> <p>Criticality safety will be relevant to individual package and overall GDF performance.</p>	<p>Nuclear properties:</p> <p>Criticality Safety</p>
Radioactive gases	Activity release (in A ₂ /day) assuming no respirable radioactive particles are released from the containers during transport).	Compatibility with transport system.	<p>Mechanical and physical properties:</p> <p>Mass transport properties</p>

Wasteform Component	Guidance Values			Reason/Comment	Relevant Performance Requirements
	3 cubic metre Box		3 cubic metre Drum		Gas generation: Radioactive gas generation
	Maximum Dimensions	Minimum Dimensions			
	4.30x 10 ⁻⁴	6.00x10 ⁻⁴			
Non-radioactive gases	Hydrogen (litres/day)			Compatibility with transport, handling and GDF design requirements. Generation of flammable gases. Post-closure migration of radionuclides. Non-radioactive gas generation will be relevant to individual package and overall GDF performance	Mechanical and physical properties: Mass transport properties Gas generation
	0.43	0.61	1.38		
	Oxygen (litres/day)				
	0.24	0.34	0.79		
Free liquids	There are no guidance values for free liquids. All reasonable measures shall be taken to exclude free liquids from the wasteform.			Containment lifetime of packaging and wasteform stability. Mobility of radioactivity following loss of containment. Free liquids will be relevant to individual package and overall GDF performance.	Immobilisation of radionuclides (all sections) Mechanical and physical properties: Mass transport properties Homogeneity/uniformity Wasteform evolution (all sections) Gas generation (all sections)

Wasteform Component	Guidance Values	Reason/Comment	Relevant Performance Requirements
Immobilisation material	<p>Choice of inorganic cements should ensure that the effective calcium to silicon ratio (Ca/Si) of the wasteform is ≥ 1.0. Alternative immobilising materials will be assessed on their compatibility with the backfill material and GDF design.</p> <p>The water permeability of the wasteform should be similar to or lower than the design permeability of the backfill.</p>	<p>Minimising the solubility of many long-lived radionuclides within the wasteform.</p> <p>Compatibility with GDF long-term pH buffering requirements.</p> <p>Controlling the mass transport properties of the wasteform.</p> <p>The choice of the immobilising material will be relevant to individual package and overall GDF performance.</p>	<p>Immobilisation of radionuclides (all sections)</p> <p>Mechanical and physical properties (all sections)</p> <p>Chemical containment (all sections)</p> <p>Hazardous materials</p> <p>Wasteform evolution (all sections)</p> <p>Gas generation (all sections)</p> <p>Nuclear properties:</p> <p>External dose rate</p>
Voidage	<p>There is no specific guidance value on waste package voidage; however voidage should be minimised.</p>	<p>Voidage in the disposal vaults may affect migration of radioactivity from a GDF, depending on GDF design.</p> <p>Increased/unpredictable chemical reaction and interactions within the wasteform.</p> <p>Accumulation of flammable gases.</p> <p>Package strength.</p> <p>Voidage will be relevant to individual package and overall</p>	<p>Immobilisation of radionuclides:</p> <p>Immobilisation of radionuclides and particulates</p> <p>Response to impact accident</p> <p>Response to fire accident</p> <p>Mechanical and physical properties:</p> <p>Strength</p> <p>Voidage</p> <p>Mass transport properties</p> <p>Homogeneity/uniformity</p> <p>Degradation processes and</p>

Wasteform Component	Guidance Values		Reason/Comment	Relevant Performance Requirements
			GDF performance.	wasteform stability: Dimensional stability Corrosion Gas generation: Gas generation by corrosion Gas generation by degradation of cellulose and other organic materials Radioactive gas generation
Metals	The corrosion of metals should not result in a linear expansion of the wasteform of more than 2,000 microstrain (ppm) during the 200 years following manufacture. This corresponds to a volumetric expansion of 0.6% (i.e. ~1.8 litres for a 3m ³ wasteform). These values given below assume complete corrosion of the stated quantity of metal which is uniformly distributed throughout the wasteform.		Values are consistent with maintenance of mechanical integrity of the wasteform during interim surface storage (assumed to be up to a maximum of 150 years), transport and the first 50 years of the operational period of a GDF.	Mechanical and physical properties: Homogeneity/uniformity Mass Thermal conductivity Chemical containment: Modification of pH buffering by wastes and other materials Wasteform evolution: Corrosion Thermal effects Gas generation:
	Corrosion Reaction	Total mass of corroding metal for 3 cubic metre wasteform	The corrosion mechanisms and rates and the nature of the reaction products are complex and need to be understood in order to define the extent of expansion due to corrosion and its consequences.	
	Mg to produce Mg(OH) ₂	40kg		

Wasteform Component	Guidance Values		Reason/Comment	Relevant Performance Requirements
	Al to produce Al(OH) ₃	22kg	Wasteform integrity will be relevant to overall waste package performance.	Gas generation by corrosion Radioactive gas generation
	U to produce UO ₂	35kg	Consideration should also be given to corrosion of metal where this may cause sufficient expansion of the wasteform to deform or threaten the integrity of the waste container.	
	Fe to produce Fe ₃ O ₄	130kg		
Organic materials	Cellulose: 60 kg per 3 cubic metre wasteform There are no guidance values for general organic material wasteform loadings. However, they may need to be restricted by their effect on the effective Ca/Si ratio of the wasteform.		Radionuclide complexant production and the potential for migration of long-lived radionuclides from a GDF. The quoted value represents the average cellulose loading of ILW wasteforms and is relevant to overall GDF performance in the long-term. Compatibility with GDF long-term pH buffering requirements.	Immobilisation of radionuclides: Response to fire accident Mechanical and physical properties Homogeneity/uniformity Thermal conductivity Chemical containment: Modification of pH buffering Complexation of radionuclides Wasteform evolution: Corrosion Radiation stability Thermal effects Gas generation (all sections)

Wasteform Component	Guidance Values	Reason/Comment	Relevant Performance Requirements
Hazardous materials	There are no guidance values for hazardous materials; however, these should be made safe. Wasteforms will be assessed on their compatibility with transport, handling and GDF authorisation for disposal.	Compatibility with transport, handling and GDF authorisation for disposal. Hazardous materials will be relevant to individual package and overall GDF performance.	Immobilisation of radionuclides: Response to an impact accident Chemical containment: Modification of pH buffering Hazardous materials Gas generation.
Minerals and ceramics	There are no guidance values for mineral and ceramic material wasteform loadings. However, they may need to be restricted by their effect on the effective Ca/Si ratio of the wasteform.	Compatibility with GDF long-term pH buffering requirements. Minerals and ceramics may be relevant to overall GDF performance.	Chemical containment: Modification of pH buffering by wastes and other materials Degradation processes and wasteform stability: Corrosion
Irradiated graphite (Wigner energy)	Wasteform loadings of graphite which has been neutron irradiated at temperatures near to those which a waste package may experience may need to be restricted. It is considered unlikely that limits will arise for graphite which has been neutron irradiated above approximately 200°C.	Effect of heating on all periods of long-term management; although transport is considered to be the most limiting case. Irradiated graphite will be relevant to individual package and overall GDF performance.	Immobilisation of radionuclides: Response to fire accident Mechanical and physical properties: Homogeneity/uniformity Wasteform evolution: Thermal effects Gas generation

Wasteform Component	Guidance Values	Reason/Comment	Relevant Performance Requirements
Materials of significance in criticality scenarios	There are no specific guidance values for materials which may be of significance in criticality scenarios (e.g. neutron moderators and reflectors) as these will be assessed on a case by case basis.	Criticality safety. Materials of significance in criticality scenarios will be relevant to individual package and overall GDF performance.	Mechanical and physical properties: Homogeneity/uniformity Nuclear properties Criticality Safety

7 REFERENCES

- 1 Nirex, *Generic Waste Package Specification*, Nirex Report N/104 Issue 2, 2007.
- 2 Nirex, *The Nirex Phased Disposal Concept*, Nirex Report N/074, 2003.
- 3 HSE/EA/SEPA, *Improved Regulatory Arrangements for the Conditioning of ILW on Nuclear Licensed Sites*. Regulators' Position Statement, 2003.
- 4 HSE/EA/SEPA, *The Management of Higher Activity Radioactive Waste on Nuclear Licensed Sites, Part I The Regulatory Process*, Guidance from the HSE, EA and SEPA to Nuclear Licensees, 2007.
- 5 IAEA, *Regulations for the Safe Transport of Radioactive Material 1996 Edition (Revised)*, IAEA Safety Standards Series No. TS-R-1 (ST-1 Revised), 2003.
- 6 British Standards Institution, *Guide to the Preparation of Specifications*, BS7373, 1998.
- 7 Nirex, *Issues to Address For Endorsement of Proposals for Packaging Wastes Containing Graphite with Wigner Energy*, Nirex Report N/058, 2002.
- 8 G. Wealthall, *The Impact of Non-aqueous Phase Liquids on Repository Performance*, British Geological Survey, Environmental Protection Programme, Internal Report Draft to Nirex v1.0, 2002.
- 9 HMSO, *Groundwater Regulations 1998*, S.I. 1998/2746, 1988.
- 10 A. Atkinson, *The Influence of Wasteform Permeability on the Release of Radionuclides from a Repository*, AERE-R11077, 1984.
- 11 R David Lide, *Handbook of Chemistry and Physics*, 77th Edition, 1996-1997.
- 12 Electrowatt-Ekono, *Calculation of Effective Thermal Conductivity for the Grouted ILW Matrix in a Repository Vault*, EWE-2916/001, 2001.
- 13 Nirex, *Topical Report on the Thermal Analysis of an ILW Repository*, Nirex Report N/086, 2003.
- 14 Nirex, *Modelling of Unshielded ILW Packages under Fire Conditions*, Nirex Report N/073, 2003.
- 15 IAEA, *Characterisation of Radioactive Waste Forms and Packages*, IAEA Technical Report Series No.383, 1997.
- 16 K Cornwell, *The Flow of Heat*, Published by the NVR Company, 1977.
- 17 British Standards Institution, *Methods for Determining Thermal Insulating Properties*, BS 874:1973.
- 18 International Patent Application No. PCT/GB94/01625, *Repository for radioactive waste - Vault backfill*, UK Nirex Ltd, International Filing date 28 July 1994.
- 19 T.G.Heath, S.J.Williams, *Effects of Organic Complexants and their Treatment in Performance Assessments*, Serco Report SA/ENV-0726, 2005.
- 20 M J Cooper, *The Nirex Safety Assessment Research Programme: Annual Report for 1987/88*, Nirex Report NSS/R133, 1989
- 21 G A Fairhall, *Effect of Process Operational Variables on the Product Properties of Encapsulated Intermediate Level Wastes*, Radioactive Waste Management 2, Volume 1, BNES 1989.
- 22 S.R. Lonsdale, S.J.Wall, *Nirex Waste Repository Dose Rate Calculations*, AEAT/Serco Report No. SA/NTD/12606001/R/01 Issue 2, 2005..

- 23 C R Wilding et. al., *The Effects of Radiation on Intermediate Level Wasteforms*, DoE/HMIP/RR/92/027.
- 24 IAEA, *Improved Cement Solidification of Low and Intermediate Level Radioactive Wastes*, IAEA Technical Series No. 350, 1993.
- 25 Nirex, *The Identification of Radionuclides Relevant to Long-term Waste Management in the United Kingdom*, Nirex Report N/105, 2004.

