

**WASTE PACKAGE SPECIFICATION AND
GUIDANCE DOCUMENTATION**

**WPS/603: Lifting Frame for 2 metre
Box Waste Package:
Description and Design Guidelines**

**March 2008
Number: 8765881**

**WASTE PACKAGE SPECIFICATION AND
GUIDANCE DOCUMENTATION**

**WPS/603: Lifting Frame for 2 metre
Box Waste Package:
Description and Design Guidelines**

**March 2008
Number: 8765881**

Conditions of Publication

This report is made available under the NDA Transparency Policy. In line with this policy, the NDA is seeking to make information on its activities readily available, and to enable interested parties to have access to and influence on its future programmes. The report may be freely used for non-commercial purposes. However, all commercial uses, including copying and re-publication, require permission from the NDA. All copyright, database rights and other intellectual property rights reside with the NDA. Applications for permission to use the report commercially should be made to the NDA Information Manager.

Although great care has been taken to ensure the accuracy and completeness of the information contained in this publication, the NDA can not assume any responsibility for consequences that may arise from its use by other parties.

© Nuclear Decommissioning Authority 2008. All rights reserved.

Bibliography

If you would like to see other reports available from NDA, a complete listing can be viewed at our website www.nda.gov.uk, or please write to the Library at the address below.

Feedback

Readers are invited to provide feedback to the NDA on the contents, clarity and presentation of this report and on the means of improving the range of NDA reports published. Feedback should be addressed to:

John Dalton,
Head of Communications,
NDA Harwell
Radioactive Waste Management Directorate
Curie Avenue,
Harwell,
Didcot,
Oxon,
OX11 0RH, UK.

john.dalton@nda.gov.uk

WASTE PACKAGE SPECIFICATION AND GUIDANCE DOCUMENTATION

**LIFTING FRAME FOR 2 METRE BOX WASTE PACKAGE: DESCRIPTION AND
DESIGN GUIDELINES**

This document forms part of a suite of documents prepared and issued by the Radioactive Waste Management Directorate (RWMD) of the Nuclear Decommissioning Authority (NDA).

The Waste Package Specification and Guidance Documentation (WPSGD) provide specifications and guidance for waste packages, containing Intermediate Level Waste and certain Low Level Wastes, which meet the transport and disposability requirements of geological disposal in the UK. They are based on, and are compatible with, the Generic Waste Package Specification (GWPS).

The WPSGD are intended to provide a 'user-level' interpretation of the GWPS to assist Site License Companies (SLCs) in the early development of plans and strategies for the management of radioactive wastes. To aid in the interpretation of the criteria defined by the WPSGD, and in their application to proposals for the packaging of wastes, SLCs are advised to contact RWMD at an early stage.

The WPSGD will be subject to periodic enhancement and revision. SLCs are therefore advised to contact RWMD to confirm that they are in possession of the latest version of any documentation used.

WPSGD DOCUMENT NUMBER WPS/603 - VERSION HISTORY

VERSION	DATE	COMMENTS
WPS/603/01	February 2006	Aligns with GWPS (Nirex Report N/104) as published June 2005
WPS/603/02	March 2008	Updated to acknowledge NDA assumption of Nirex responsibilities Aligns with Issue 2 of GWPS (Nirex Report N/104) as published March 2007.

This document has been compiled on the basis of information obtained by Nirex and latterly by the NDA. The document was verified in accordance with arrangements established by the NDA that meet the requirements of ISO 9001. The document has been fully verified and approved for publication by the NDA.

1 INTRODUCTION

The Radioactive Waste Management Directorate (RWMD) of the Nuclear Decommissioning Authority (NDA) has been established with the remit to implement the geological disposal option for the UK's higher activity radioactive wastes. The NDA is currently working with Government and stakeholders through the *Managing Radioactive Waste Safely* (MRWS) consultation process to plan the development of a Geological Disposal Facility (GDF).

As the ultimate receiver of wastes, RWMD, acting as GDF implementer and future operator, has established waste packaging standards and defined package specifications to enable the industry to condition radioactive wastes in a form that will be compatible with future transport and disposal. In this respect RWMD is taking forward waste packaging standards and specifications which were originally developed by United Kingdom Nirex Ltd, which ceased trading on 1st April 2007 and whose work has been integrated into the NDA.

The primary document which defines the packaging standards and specifications for Intermediate Level Waste (ILW), and certain Low Level Wastes (LLW) not suitable for disposal in other LLW facilities is the Generic Waste Package Specification (GWPS) [1]. The GWPS is supported by the Waste Package Specification and Guidance Documentation (WPSGD) which comprises a suite of documentation primarily aimed at SLCs, its intention being to present the generic packaging standards and specifications at the user level. The WPSGD also includes explanatory material and guidance that users will find helpful when it comes to application of the specification to practical packaging projects. For further information on the extent and the role of the WPSGD, reference should be made to the *Introduction to the Waste Package Specification and Guidance Documentation, WPS/100*¹.

In order to facilitate the safe and efficient packaging, transport and disposal of ILW/LLW, RWMD has defined a limited range of standard containers and has issued specifications that define the dimensions, lifting, handling and other key features of these together with minimum performance requirements for the complete waste package.

This document provides design basis information for a standard lifting frame suitable for handling the 2 metre Box waste packages (Figure 1). It has been issued to accompany, and should therefore be read in conjunction with the relevant specifications and guidance for that waste package, namely:

WPS/350: Specification for 2 metre Box Waste Package

WPS/750: 2 metre Box Waste Package Specification: Guidance Material and Design Guidelines

In the absence of detailed designs for lifting and handling equipment, the waste package specifications have been progressed by making reasonable assumptions regarding the design concepts which will be adopted for the lifting equipment. These design basis assumptions may impact on the design of waste containers and are therefore set down in

¹ Specific references to individual documents within the WPSGD are made in this document in *italic script*, followed by the relevant WPS number.

this document so that designers of waste containers and waste package handling equipment may be aware of them.

2 PURPOSE

The purpose of this document is to supplement the information provided in *WPS/350* by providing design basis information on the lifting frame which has been assumed in the derivation of specifications for the 2 metre Box waste package. This document defines the interface between waste packages and the lifting frame and will be of use to designers of waste containers and handling equipment alike.

This document should not be considered as a full specification of the lifting frame since its scope is limited to consideration of those factors which have an impact on the specification of waste package design and performance.

3 GENERAL DESCRIPTION OF THE LIFTING FRAME

3.1 Function of the Lifting Frame

The function of the lifting frame is to ensure that 2 metre Box waste packages can be handled in a safe manner by remote operation and lifted by overhead crane, stacker truck or other handling equipment.

3.2 Design Assumptions

The following are assumptions regarding the design of lifting frame which have been made in the derivation of *WPS/350*:

- The lifting frame will be designed to handle 2 metre Box waste packages with a maximum gross mass of 40t.
- The lifting frame will be designed to handle the waste packages by means of four-point lifting. Four-point lifting will be used to provide a degree of redundancy and to minimise tilting due to load imbalance.
- The frame will be designed in accordance with BS 2573 [2] which specifies the classification, stress calculations and design criteria for crane structures. The group classification, as defined in BS 2573, is assumed to be 'A3', with a class of utilisation 'U3' (infrequent use) which in turn implies a state of loading 'Q2' (moderate loading).
- The frame will be designed to handle waste packages with asymmetric load distribution.
- The frame will incorporate lifting twistlocks meeting the general requirements of BS 5237 [3] but designed for a much higher load rating, to locate and attach the lifting frame to the waste package. Although the design of the overall lifting frame has yet to be considered, the design of the non-standard twistlocks has been completed and details are provided in [4].

- The twistlocks will be of the true horizontal floating type, as defined in BS 5237, to enable them to position themselves separately with respect to the lifting attachments on the waste packages.
- The twistlocks will be housed within a locating spigot, of the type defined in BS 5237, designed to locate the twistlock in the corner fitting on the waste package. The lifting frame will be provided with location guides at each corner which will engage on the outside edge of the waste package corner fittings.
- Measures will be incorporated in the design of the lifting frame to minimise the risk of inadvertent release or other mishandling of packages. These are likely to include limit and/or probe switches and appropriate warnings to indicate the status of the twistlocks, and interlocks to detect the presence of a load and prevent unlocking of the twistlocks when laden, and a 'slack rope' interlock to indicate when the lifting frame has been lowered on to the container. In the event of failure of the lifting frame whilst attached to a waste package, measures will be provided to allow the package to be lowered in a controlled manner and disengaged from the lifting frame by remote means. The consequences of a collision with a stationary object whilst laden will be considered in order to minimise the risk of releasing the package.

4 KEY INTERFACING INFORMATION

4.1 General

The lifting frame interfaces with the waste package is effected solely via the twistlocks and locating spigots. To ensure proper operation of the lifting frame with the waste package it is essential that the lifting features on the waste packages should comply with the requirements defined in *WPS/350*.

The following additional information is provided to assist with design of the lifting feature.

4.2 Twistlock details

The maximum gross mass of a 2 metre Box waste package is 40t. The nominal load to be supported by each twistlock would therefore be 10t. However the Safe Working Load (SWL) for such lifting equipment must be specified to take account of additional factors such as uneven load distribution, tilt and snatch loads, together with RWMD's requirement that the twistlocks and frame will be capable of supporting the package at 3 points in the event of a failure of a lifting point. All of the above factors will serve to increase the SWL requirements of the individual twistlocks.

When determining the rating of the lifting equipment it is assumed that the twistlocks are of the true horizontal floating type with a float of 5mm, a maximum load asymmetry of 60%/40% in the longitudinal direction and a maximum lateral C of G offset of 150mm. A snatch load factor of 1.3 is also assumed in the design. The combination of these effects leads to a maximum dynamic loading, on the most loaded twistlock, of 14.2t for 4 point lifting.

Twistlocks suitable for lifting 4 metre Box waste packages with a maximum gross mass of 65t have been designed [4] and prototypes have been built and tested. Clearly these twistlocks would also be capable of satisfying the less onerous lifting requirements for a

WPS/603/02
March 2008

2 metre Box waste package with a maximum gross mass of 40t. The general shape and the features of the twistlocks are as defined in BS 5237 (with major dimensions at the maximum allowed under the standard) and differ only in respect of the fact that the maximum SWL rating allowed under BS 5237 is 13t, whereas twistlocks designed for the 2 metre Box waste package have a SWL rating of 22.3t and are proof tested to 44.6t. A key feature which determines the SWL of a twistlock is the diameter of the undercut between the twistlock shank and the twistlock head. This has been maximised at 58mm in the developed design and is within the limits allowed by BS 5237. Particular attention has also been given to the nut and thread by which the twistlocks are suspended from the lifting frame. The high loadings placed on these items requires a special nut be developed. The main dimensions of the twistlock are shown in Figure 2.

4.3 Locating Spigot Details

Spigot design requirements are specified in BS 5237. The spigot dimensions are determined by the major dimensions of the twistlock and are such that they ensure that when the twistlock is in the unlocked position the head of the twistlock does not extend beyond the outer dimensions of the spigot.

The major dimensions of the spigots to be employed on the lifting frame are shown in Figure 3 (based on Figure 2 in BS 5237, to which reference may be made for other design details not shown).

4.4 Twistlock Insertion Depth

For the purpose of designing the top (lifting) corner fittings on the waste package the maximum depth of the combination of spigot and twistlock head shall be taken to be 127mm as indicated on Figure 3. The minimum spigot depth will be 66mm and therefore the thickness of the aperture face of the corner fitting is to be a maximum of 56mm. This will ensure that when the twistlock is inserted into the corner fitting there will be a minimum 10mm clearance between the twistlock head bearing surface, similar to that recommended for ISO freight containers.

4.5 Twistlock/Corner Fitting Positions

The nominal positions of the corner fittings on the waste packages are defined in *WPS/350* and for ease of reference are repeated here in Figure 4.

The same nominal positions will be used for the positioning of the twistlocks on the lifting frame. Limits on the positioning of the twistlocks, making allowance for float, should be determined by designers in accordance with the recommendations in Appendix A of BS 5237.

Figure 1 2 metre Box Waste Package

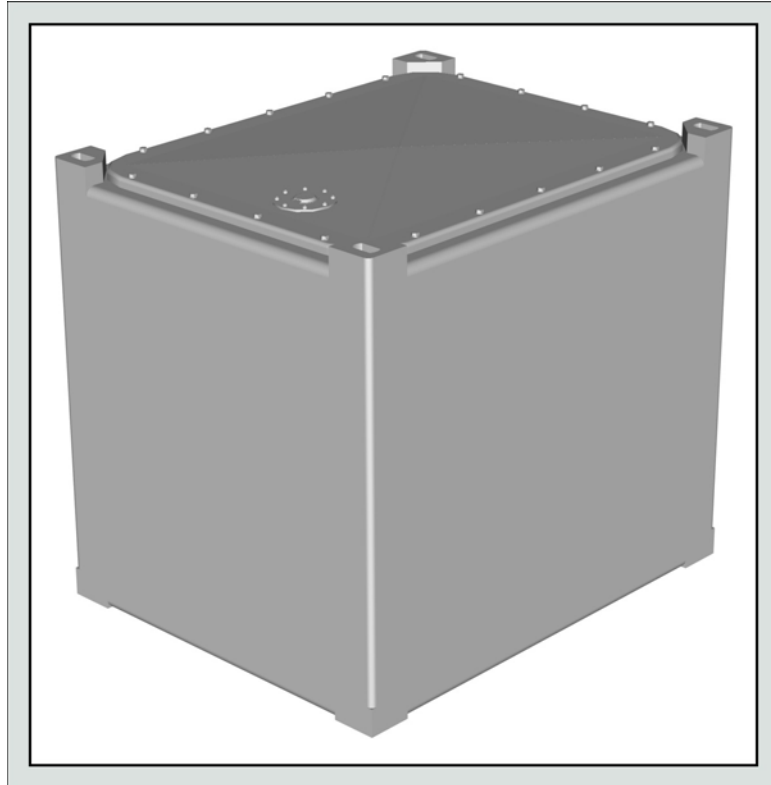
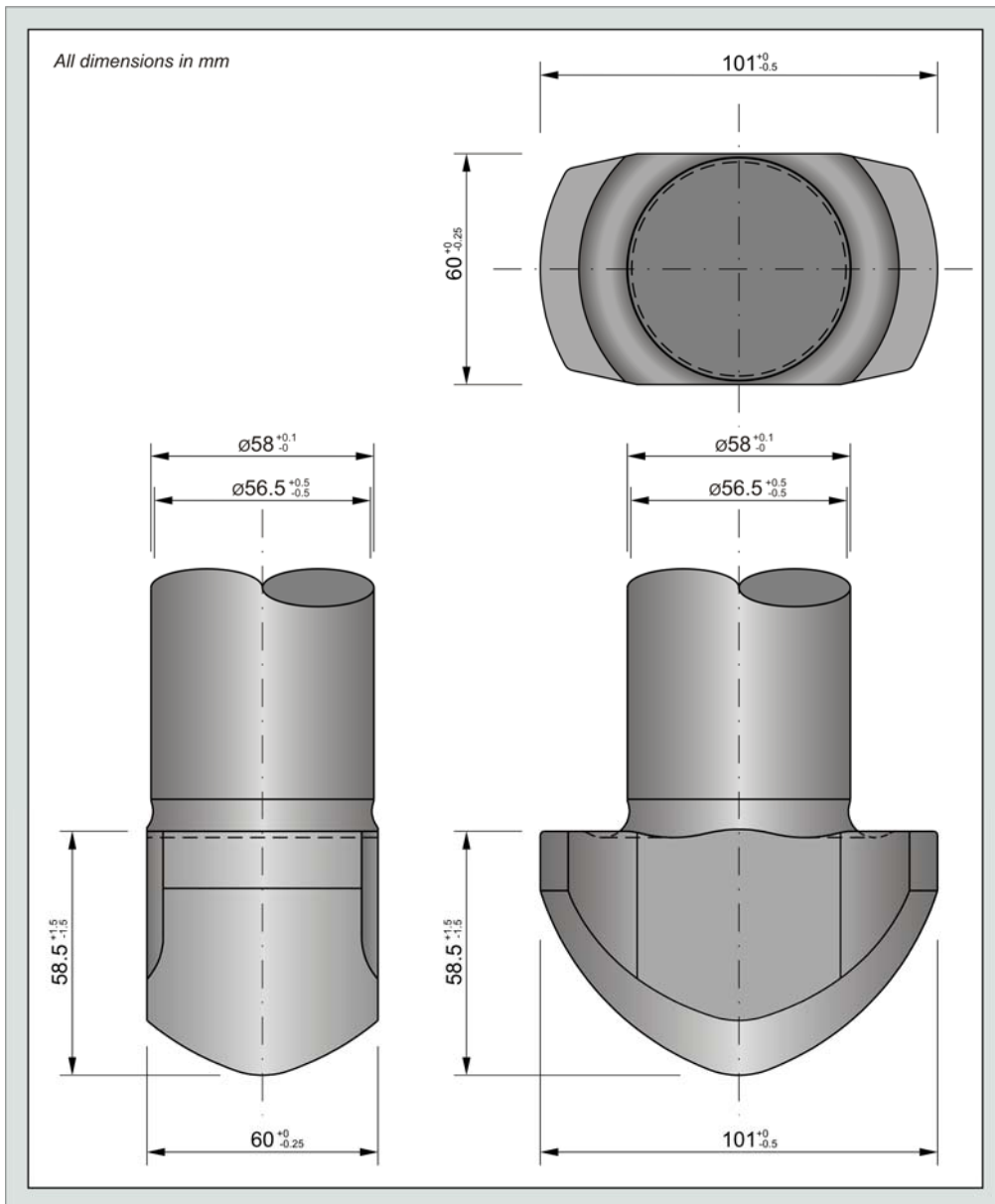
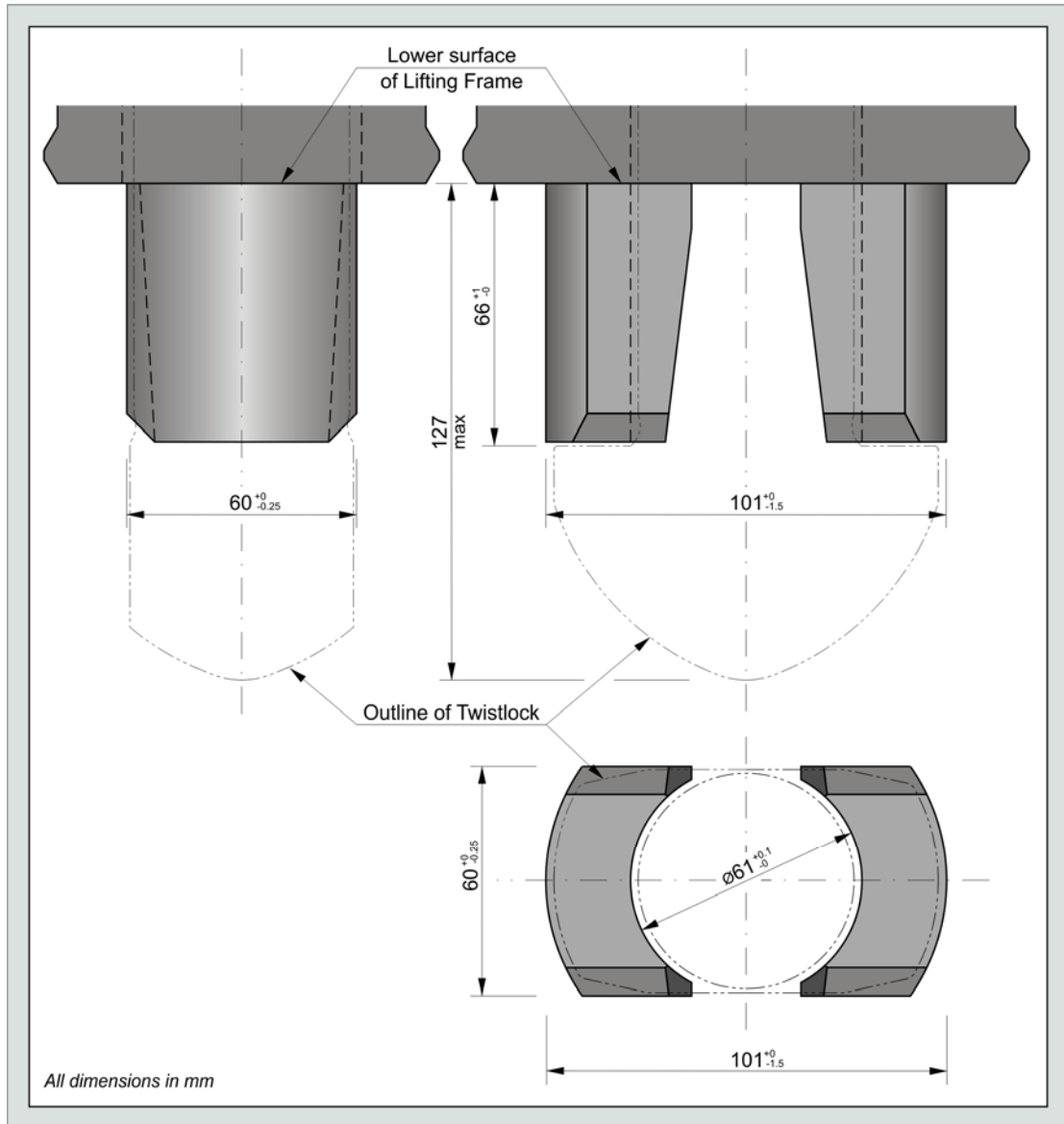

Figure 2 Twistlock Dimensions²



² Based on Figure 1 in BS 5237 [3] to which reference may be made for other design details not shown.

Figure 3 Locating Spigot Dimensions³



³ Based on Figure 2 in BS 5237 [3] to which reference may be made for other design details not shown.

Figure 4 Location of Corner Fittings

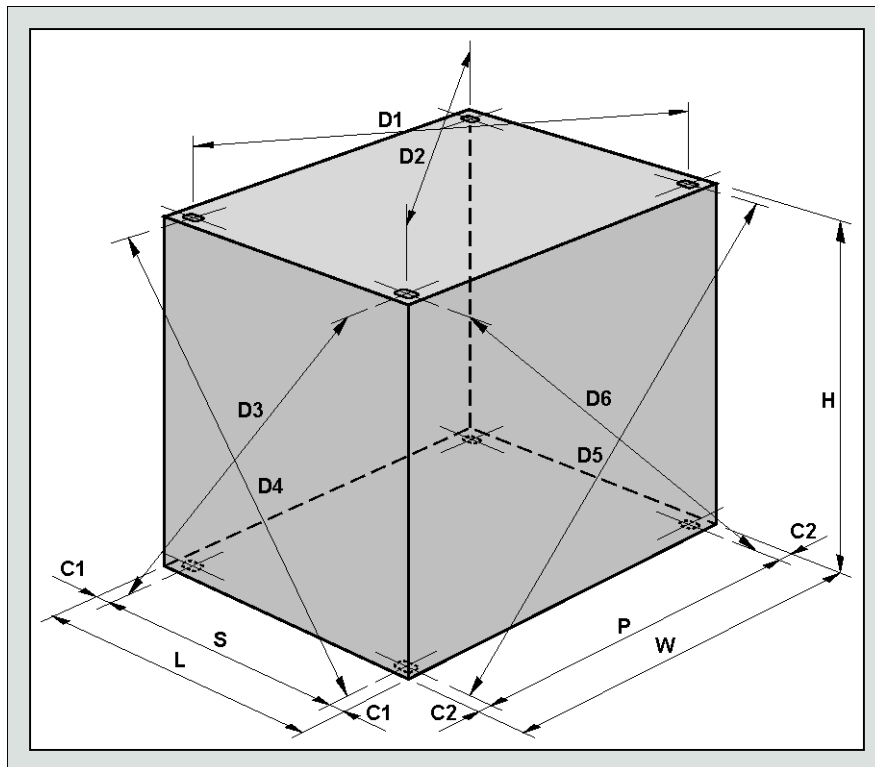

KEY

Label	Description	Dimension (mm)	Tolerance (mm)
L	Overall Box Length	1969	+0/-6
W	Overall Box External Width	2438	+0/-5
H	Overall Box External Height	2200	+0/-5
S	Length between Corner Fitting Aperture Centres	1765	ref.
P	Width between Corner Fitting Aperture Centres	2259	ref.
K1	Difference between D1 & D2 or D3 & D4 i.e. $ D1-D2 $ or $ D3-D4 $	9	max.
K2	Difference between D5 & D6 i.e. $ D5-D6 $	11	max.
C1	Corner Fitting Measurement ⁴	101.5	+0/-1.5
C2	Corner Fitting Measurement	89.0	+0/-1.5

⁴ from BS3951: Pt. 1: Section 1.2: 1985

5 REFERENCES

- 1 Nirex, *Generic Waste Package Specification*, Nirex Report N/104 Issue 2, 2007.
- 2 British Standards Institution, *British Standard Rules for Design of Cranes, Part 1 Specification for classification, stress calculations and design for structures*, BS 2573: Part 1: 1983.
- 3 British Standards Institution, *British Standard Specification for Lifting Twistlocks*, BS 5237: 1985.
- 4 Nirex, *Design, Manufacture and Test of a Lifting Twistlock to suit Nirex Lifting Frame for 65 Tonne Waste Packages*, T/REP/20138, 1997.

