

**WASTE PACKAGE SPECIFICATION AND  
GUIDANCE DOCUMENTATION**

**WPS/520: Wasteform Specification for  
2 metre Box and  
4 metre Box Waste Packages**

**March 2008  
Number: 8766490**



**WASTE PACKAGE SPECIFICATION AND  
GUIDANCE DOCUMENTATION**

**WPS/520: Wasteform Specification for  
2 metre Box and  
4 metre Box Waste Packages**

**March 2008  
Number: 8766490**

## **Conditions of Publication**

This report is made available under the NDA Transparency Policy. In line with this policy, the NDA is seeking to make information on its activities readily available, and to enable interested parties to have access to and influence on its future programmes. The report may be freely used for non-commercial purposes. However, all commercial uses, including copying and re-publication, require permission from the NDA. All copyright, database rights and other intellectual property rights reside with the NDA. Applications for permission to use the report commercially should be made to the NDA Information Manager.

Although great care has been taken to ensure the accuracy and completeness of the information contained in this publication, the NDA can not assume any responsibility for consequences that may arise from its use by other parties.

© Nuclear Decommissioning Authority 2008. All rights reserved.

## **Bibliography**

If you would like to see other reports available from NDA, a complete listing can be viewed at our website [www.nda.gov.uk](http://www.nda.gov.uk), or please write to the Library at the address below.

## **Feedback**

Readers are invited to provide feedback to the NDA on the contents, clarity and presentation of this report and on the means of improving the range of NDA reports published. Feedback should be addressed to:

John Dalton,  
Head of Communications,  
NDA Harwell  
Radioactive Waste Management Directorate  
Curie Avenue,  
Harwell,  
Didcot,  
Oxon,  
OX11 0RH, UK.

[john.dalton@nda.gov.uk](mailto:john.dalton@nda.gov.uk)

**WASTE PACKAGE SPECIFICATION AND GUIDANCE DOCUMENTATION**

**WASTEFORM SPECIFICATION FOR 2 METRE BOX AND 4 METRE BOX WASTE  
PACKAGES**

This document forms part of a suite of documents prepared and issued by the Radioactive Waste Management Directorate (RWMD) of the Nuclear Decommissioning Authority (NDA).

The Waste Package Specification and Guidance Documentation (WPSGD) provide specifications and guidance for waste packages, containing Intermediate Level Waste and certain Low Level Wastes, which meet the transport and disposability requirements of geological disposal in the UK. They are based on, and are compatible with, the Generic Waste Package Specification (GWPS).

The WPSGD are intended to provide a 'user-level' interpretation of the GWPS to assist Site License Companies (SLCs) in the early development of plans and strategies for the management of radioactive wastes. To aid in the interpretation of the criteria defined by the WPSGD, and in their application to proposals for the packaging of wastes, SLCs are advised to contact RWMD at an early stage.

The WPSGD will be subject to periodic enhancement and revision. SLCs are therefore advised to contact RWMD to confirm that they are in possession of the latest version of any documentation used.

<b>WPSGD DOCUMENT NUMBER WPS/520 - VERSION HISTORY</b>		
<b>VERSION</b>	<b>DATE</b>	<b>COMMENTS</b>
WPS/520/01	November 2005	Aligns with GWPS (Nirex Report N/104) as published June 2005
WPS/520/02	March 2008	Responsibility for the WPSGD passed to the NDA RWMD. Aligns with Issue 2 of GWPS (Nirex Report N/104) as published March 2007.

This document has been compiled on the basis of information obtained by Nirex and latterly by the NDA. The document was verified in accordance with arrangements established by the NDA that meet the requirements of ISO 9001. The document has been fully verified and approved for publication by the NDA.



## 1 INTRODUCTION

The Radioactive Waste Management Directorate (RWMD) of the Nuclear Decommissioning Authority (NDA) has been established with the remit to implement the geological disposal option for the UK's higher activity radioactive wastes. The NDA is currently working with Government and stakeholders through the *Managing Radioactive Waste Safely* (MRWS) consultation process to plan the development of a Geological Disposal Facility (GDF).

As the ultimate receiver of wastes, RWMD, acting as GDF implementer and future operator, has established waste packaging standards and defined package specifications to enable the industry to condition radioactive wastes in a form that will be compatible with future transport and disposal. In this respect RWMD is taking forward waste packaging standards and specifications which were originally developed by United Kingdom Nirex Ltd, which ceased trading on 1<sup>st</sup> April 2007 and whose work has been integrated into the NDA.

The primary document which defines the packaging standards and specifications for Intermediate Level Waste (ILW), and certain Low Level Wastes (LLW) not suitable for disposal in other LLW facilities is the Generic Waste Package Specification (GWPS) [1]. The GWPS is supported by the Waste Package Specification and Guidance Documentation (WPSGD) which comprises a suite of documentation primarily aimed at waste packagers, its intention being to present the generic packaging standards and specifications at the user level. The WPSGD also includes explanatory material and guidance that users will find helpful when it comes to application of the specification to practical packaging projects. For further information on the extent and the role of the WPSGD, reference should be made to the *Introduction to the Waste Package Specification and Guidance Documentation, WPS/100*<sup>1</sup>.

In order to facilitate the safe and efficient packaging, transport and disposal of radioactive waste, RWMD has defined a limited range of standard waste containers. Included within the WPSGD are documents which define standards and specifications for the waste packages that are created using these containers, together with specifications for the wasteforms contained within them. For each standard waste package a suite of four documents exists:

- WPS/300 Series – Waste Package Specification
- WPS/500 Series – Wasteform Specification
- WPS/700 Series – Guidance on Waste Package Specification
- WPS/800 Series – Guidance on Wasteform Specification

This document provides a specification for the wasteform for the 2 metre Box and 4 metre Box waste packages. It should be read in conjunction with the relevant WPS/300 and WPS/700 Series documents, namely:

- *Specification for 2 metre Box Waste Package, WPS/350*
- *Specification for 4 metre Box Waste Package, WPS/330*

---

<sup>1</sup> Specific references to individual documents within the WPSGD are made in this document in *italic script*, followed by the relevant WPS number.

and:

- *2 metre Box Waste Package: Guidance Material and Design Guidelines, WPS/750*
- *4 metre Box Waste Package: Guidance Material and Design Guidelines, WPS/730*

Reference should also be made to *2 metre Box and 4 metre Box Wasteform Specification: Explanatory Material and Guidance, WPS/820*, which provides background information, guidance and advice on the interpretation of this specification.

## **2 BACKGROUND**

### **2.1 The Concept of Geological Disposal**

A key aspect in the production of standard and specifications for packaged waste is the definition of a disposal system which encompasses all stages of the long-term management of waste from retrieval through to final disposal.

In line with the MRWS consultation process, RWMD are continuing to develop concepts for the geological disposal for higher activity wastes which include ILW, and certain LLW not suitable for disposal in other LLW facilities<sup>2</sup>. It is envisaged that the geological disposal of such wastes would comprise a number of distinct stages including:

- the retrieval and conditioning of the waste to create disposable waste packages, usually at the site of waste arising;
- a period of interim surface storage, also at the site of arising;
- transport of the waste packages to a GDF;
- transfer of waste packages underground and emplacement in disposal vaults;
- a period of monitored storage underground, during which retrieval by relatively simple means would be feasible;
- back-filling of the disposal vaults, followed by eventual sealing and closure.

The timing and duration of each stage would depend on a number of criteria, including the geographical location and host geology of a GDF as well as the disposal concept selected for implementation.

The Phased Geological Repository Concept (PGRC) [2], has been developed as one manifestation of geological disposal and has been adopted as the reference concept for the purposes of establishing packaging standards. The PGRC is supported by a suite of safety, security and environmental assessments intended to demonstrate that this concept will provide safety to workers and the public and provide the necessary level of environmental protection.

The safety philosophy adopted in the PGRC, in common with other approaches to the geological disposal of radioactive waste, is one of containment of radionuclides by multiple barriers, of which that provided by the waste package is a key component. Included in these barriers are those provided by the waste package, which itself can be considered as two independent but complimentary barriers, the waste container and the wasteform, each of which plays an important role in the containment of radionuclides.

---

<sup>2</sup> The generic description 'ILW' is used in the remainder of this document to describe both these categories of waste.

As the MRWS consultation process continues it is anticipated that the siting process, based on expressions of interest from volunteer communities, may lead to the identification of sites for investigation as to suitability to host a GDF. The disposal concept design and safety case will be developed to suit the specific characteristics of the site and packaging standards will be updated to reflect the new circumstances as appropriate.

## **2.2 The Generic Waste Package Specification**

A major area of the RWMD's work is the provision of advice to the packagers of radioactive waste in the UK, by way of the definition of packaging standards and the assessment of individual waste packaging proposals against those standards.

The primary document that defines packaging standards for ILW is the GWPS [1]. Derived from the PGRC and its associated generic documentation, which comprise the system specifications and safety assessments that define the PGRC, the GWPS provides the basis for assessing the suitability of waste packages containing ILW for disposal in a GDF.

The packaging standards defined by the GWPS are generic in two respects in that they are:

- derived from a full consideration of all future stage of long-term waste management; and
- independent of the location of the site of a GDF, which could be implemented at a range of different sites within the UK, representing a range of geological environments.

The format of the GWPS is to define:

- general requirements that are applicable to all waste packages;
- a range of standard waste containers;
- specific requirements for the standard waste package design that are created using the standard waste containers;
- requirements for the conditioned wasteforms that are placed into containers;
- requirements for quality management and for the creation and maintenance of records about each individual waste package.

The GWPS therefore defines the performance requirements for the two barriers to the release of radionuclides provided by the waste package, the waste container and the wasteform, against which the overall performance of waste packages can be assessed.

## **2.3 The Assessment of Packaging Proposals**

Since the mid-1980s, waste producers in the UK have made significant investment in waste retrieval and packaging plant as a means of ensuring that such wastes are rendered passively safe and suitable for disposal. Historically Nirex was responsible for the assessment and endorsement of the suitability of packaging processes for this latter need, originally by way of the 'Letter of Comfort' assessment process. Over the ensuing two decades the Letter of Comfort process has developed and matured to a point that the assessments undertaken were established on a more structured footing with detailed advice being issued to waste producers highlighting further information needs, or need for further development and/or research before a Letter of Comfort could be issued. The assessment process was also modified to integrate better with the implementation of packaging plant projects, with staged interactions occurring at a number of stages before active operation of a packaging plant commenced. The status of the assessment process was strengthened in January 2004, when support was provided by UK nuclear regulators, and it was recognised within improved regulatory arrangements for nuclear

**WPS/520/02**  
**March 2008**

licensed sites [3]. This was accompanied by significant changes to the assessment process which was renamed the 'Letter of Compliance' assessment process, a full description of which can be found in *Guide to the Letter of Compliance Assessment Process*, WPS/650.

In April 2007 Nirex was dissolved and its responsibilities assumed by RWMD. This included the role of assessing and endorsing nuclear site operators' waste packaging proposals through the LoC assessment process.

In undertaking LoC assessments RWMD determines whether wastes, when packaged, will have characteristics compliant with plans for transport to, and operations at a GDF, and ultimately whether the wastes could be accommodated within a GDF long-term post-closure safety case. The main output of a LoC assessment is an Assessment Report which may be accompanied by the issue of a LoC endorsing the packaging proposal. In line with the recently updated regulatory guidance [4] such endorsement is now seen by the regulators as an important component of the operator's Radioactive Waste Management Case.

### **3 THE 2 METRE BOX AND 4 METRE BOX WASTE PACKAGES**

The 2 metre Box (Figure 1) and 4 metre Box (Figure 2) waste packages are two of a limited range of standard waste packages defined by the GWPS. They are essentially freight containers that are intended to be used predominantly for the conditioning of ILW arising from the decommissioning of redundant nuclear facilities.

The 2 and 4 metre Box waste packages are 'shielded waste packages' in that, where necessary, they will have built-in shielding and/or contain low activity materials, such that they do not need remote handling techniques. In view of the wide range of activities of the wastes that could be conditioned in 2 and 4 metre Box waste packages it is anticipated that four different shielding thicknesses could be used; 0mm, 100mm, 200mm and 300mm, although it is unlikely that 2 metre Box waste packages with 300mm of shielding would represent an efficient option for the conditioning and disposal of ILW.

As well as being suitable for disposal in a GDF, 2 and 4 metre Box waste packages are specified in such a manner as to qualify as transport packages in their own right. They are capable of being transported through the public domain without the need for an overpack to provide additional radiation shielding and/or containment. The 2 and 4 metre Box waste packages are classed as an Industrial Package Type 2 (Type IP-2) under the IAEA Transport Regulations [5] and as such, the allowable contents are limited to materials that qualify as Low Specific Activity (LSA) material and/or Surface Contaminated Objects (SCO).

Figure 1 2 metre Box waste package

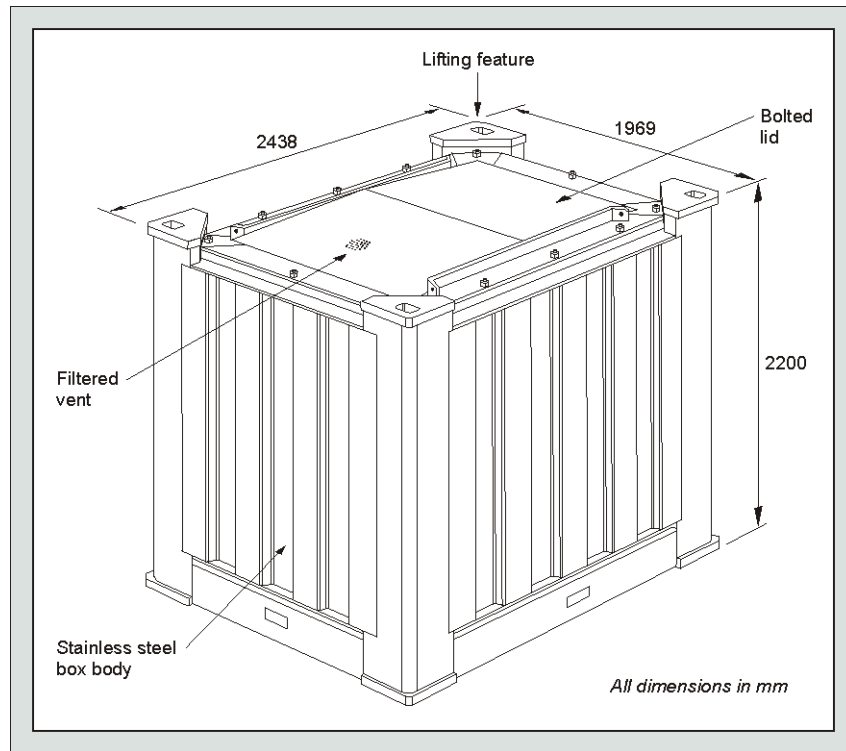
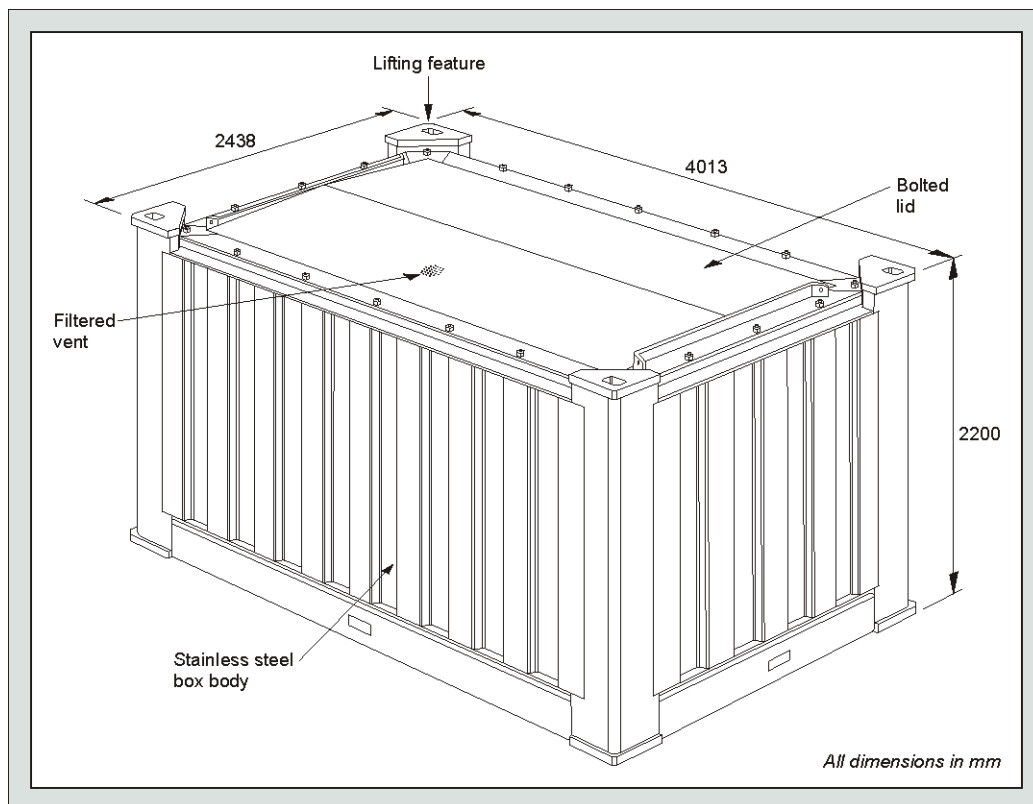

Figure 2 4 metre Box waste package



## **4 WASTEFORM PROPERTIES**

This section identifies the performance criteria that are required of the wasteforms for all waste packages manufactured using the 2 and 4 metre Box waste container, specified to ensure the compatibility of such waste packages with the needs of all stages of their long-term management. Where numerical criteria are specified the values stated are those that would be applicable at the time of transport from the waste packager's site (unless specifically stated otherwise).

It should be noted that, where the words *shall* and *should* are used in criteria within this Specification, their use is consistent with the recommendations of BS 7373:1998 [6] and that they have the following meaning:

- *shall* denotes a criterion which is derived from consideration of a regulatory requirement and/or which forms the basis for package standardisation;
- *should* denotes a criterion which is considered as a target, and for which variations may be possible following discussion with RWMD.

### **4.1 Nature of Contents**

The wasteform shall be capable of being categorised as Low Specific Activity (LSA) material or Surface Contaminated Objects (SCO) and of being excepted from the IAEA Transport Regulations requirements for transport packages containing fissile material.

### **4.2 Physical Immobilisation**

The wasteform shall be designed to immobilise radionuclides and toxic materials so as to ensure appropriate waste package performance during all stages of long-term management. For many wastes, this immobilisation requires the use of an encapsulating matrix.

#### **4.2.1 Immobilisation of Radionuclides and Particulates**

All reasonable measures shall be taken to ensure that radionuclides and toxic materials in the waste are immobilised and that loose particulate material is minimised.

#### **4.2.2 Response to an Impact Accident**

All reasonable measures shall be taken to ensure that, in the event of an impact accident, the quantity of potentially mobile radionuclides present within the waste package, including those generated as a result of the impact accident, is commensurate with the waste package meeting the relevant radioactivity release limits specified in the relevant WPS/300 Series Specification.

#### **4.2.3 Response to a Fire Accident**

All reasonable measures shall be taken to ensure that, in the event of a fire accident, the quantity of potentially mobile radionuclides present within the waste package, including those generated as a result of the fire accident, is commensurate with the waste package meeting the relevant radioactivity release limits specified in the relevant WPS/300 Series Specification.

In addition, the wasteform should not readily burn or otherwise support combustion.

#### **4.2.4 Free liquids**

All reasonable measures shall be taken to exclude free liquids from the wasteform. This should include materials that may degrade to generate liquids. Free liquids not removed from wastes prior to waste packaging should be immobilised by a suitable waste conditioning process.

### **4.3 Mechanical and Physical Properties**

The wasteform shall be designed to provide the mechanical and physical properties necessary to ensure appropriate performance of the waste package during all stages of long-term management.

#### **4.3.1 Mechanical Strength**

The wasteform shall provide sufficient mechanical strength to allow the waste package to be transported and handled without affecting the ability of the waste package to meet all the requirements of the relevant WPS/300 Series Specification.

#### **4.3.2 Voidage**

The development and production of the wasteform should ensure that the volume of voidage within the waste package (such as ullage, holes or other spaces) is minimised.

#### **4.3.3 Mass-Transport Properties**

The wasteform shall be sufficiently permeable to allow gases generated within the wasteform to be released without compromising the ability of the waste package to meet any aspect of the relevant WPS/300 Series Specification.

The mass transport properties of the wasteform (e.g. diffusivity and permeability) shall provide best practicable means for containment of water-soluble radionuclides within the waste package.

#### **4.3.4 Homogeneity/Uniformity**

Local concentrations of materials within the wasteform that may compromise the ability of the waste package to meet any aspect of the relevant WPS/300 Series Specification should be avoided.

#### **4.3.5 Thermal Conductivity**

The thermal conductivity of the wasteform shall be sufficient to dissipate any heat generated within the waste package, when emplaced in a GDF, without unacceptable temperature rise. The minimum value of thermal conductivity should be  $0.5\text{Wm}^{-1}\text{K}^{-1}$ .

#### **4.3.6 Leachability**

Wasteforms categorised as LSA-III material shall be sufficiently insoluble as to satisfy the requirements of Paragraph 226 (c) (ii) of the IAEA Transport Regulations.

### **4.4 Chemical Containment**

The wasteform shall not be incompatible with the chemical containment of radionuclides and hazardous materials as embodied in the requirements of a GDF.

Where they may affect chemical containment, the following items should not be introduced through waste conditioning or packaging, and their presence in wastes should be minimised wherever practicable:

- Oxidising agents;
- Acids and/or materials that degrade to generate acids;
- Cellulose and other organic materials;
- Complexants and chelating agents, and/or materials that degrade to generate such compounds;

- Non Aqueous Phase Liquids (NAPLs) and/or materials that degrade to generate them;
- Any other materials that could detrimentally affect chemical containment.

#### **4.5 Hazardous Materials**

The wasteform shall not contain hazardous<sup>3</sup> materials, or have the potential to generate such materials, unless the treatment and packaging of such materials or items makes them safe. The means by which any of these materials is made safe shall be demonstrable for all relevant periods of long-term management.

#### **4.6 Gas Generation**

Gases generated by the wasteform shall not compromise the ability of the waste package to meet any aspect of the relevant WPS/300 Series Specification.

#### **4.7 Wasteform Evolution**

Changes in the characteristics of the wasteform as it evolves shall not result in degradation that will compromise the ability of the waste package to meet any aspect of the relevant WPS/300 Series Specification.

The deleterious effects of the following processes should be considered:

- dimensional changes, e.g. shrinkage;
- corrosion including, but not limited to, the production of gases and particulate material, and wasteform expansion resulting from the formation of lower density solid corrosion products;
- microbial activity;
- self-irradiation and irradiation by surrounding waste packages;
- heat generation by the wasteform and its surroundings including, but not limited to, localised heat sources within the wasteform, the effects on the curing of the encapsulant material and the consequential effects on longer-term performance.

#### **4.8 Nuclear Properties**

##### **4.8.1 External Dose Rate**

The radionuclide content and nature of the wasteform should ensure that waste package external dose rate limits as specified in the relevant WPS/300 Series Specification are complied with at the time of transport.

##### **4.8.2 Criticality Safety**

The presence of fissile materials, neutron moderators and reflectors in the waste package shall be controlled to ensure that they do not present a criticality safety hazard during any of the active stages of their long-term management.

---

<sup>3</sup> Including flammable, explosive, pyrophoric, chemo-toxic and oxidising materials; sealed and/or pressurised containers; and/or mechanical devices containing stored energy.

It shall also be ensured that, following closure of a GDF, the possibility of local accumulation of fissile material such as to produce a neutron chain reaction is not a significant concern to the long-term performance of a GDF.

## **5 REFERENCES**

---

- 1 Nirex, *Generic Waste Package Specification*, Nirex Report N/104 Issue 2, 2007.
- 2 Nirex, *The Nirex Phased Disposal Concept*, Nirex Report N/074, 2003.
- 3 HSE/EA/SEPA, *Improved Regulatory Arrangements for the Conditioning of ILW on Nuclear Licensed Sites. Regulators' Position Statement*, 2003.
- 4 HSE/EA/SEPA, *The Management of Higher Activity Radioactive Waste on Nuclear Licensed Sites, Part I The Regulatory Process*, Guidance from the HSE, EA and SEPA to Nuclear Licensees, 2007.
- 5 IAEA, *Regulations for the Safe Transport of Radioactive Material, 1996 Edition (Revised)*, IAEA Safety Standards Series No. TS-R-1 (ST-1, Revised), 2003.
- 6 British Standards Institution, *Guide to the Preparation of Specifications*, BS7373, 1998.





